
HeadsUp: A Head-Mounted Distance Response Device for the Blind

Submitted in fulfillment of the requirements of
EEL 4914 Senior Design

By

Group 14

Duc-Quy Nguyen (Photonic Science & Engineering)

Alex Radulescu (Electrical Engineering)

Austin Singh (Photonic Science & Engineering)

Hunter Tanchin (Computer Engineering)

Under the supervision of:

Dr. David J. Hagan (CREOL - Optics & Photonics, Physics)

Dr. Samuel M. Richie (CECS - Electrical & Computer Engineering)

&

Dr. Lei Wei (CECS - Electrical & Computer Engineering)

The University of Central Florida College of Engineering and Computer
Science (CECS) & College of Optics and Photonics (CREOL)

3 December 2018

Table of Contents

1.	Executive Summary	1
2.	Project Description	3
2.1.	Project Background.....	3
2.2.	Objectives.....	4
2.3.	Requirement Specifications.....	5
2.3.1.	Hardware.....	6
2.3.1.1.	Microcontroller.....	6
2.3.1.2.	Laser Transmitter and Receiver.....	7
2.3.1.3.	Power Source.....	8
2.3.1.4.	User Interface.....	8
2.3.2.	Software.....	9
2.4.	House of Quality.....	10
2.5.	Hardware Responsibilities.....	12
3.	Research related to Project Definition	14
3.1.	Existing Similar Projects and Products.....	14
3.1.1.	Ultracane.....	14
3.1.2.	WeWalk.....	15
3.1.3.	Blindsquare.....	16
3.1.4.	Navigon.....	17
3.1.5.	BeMyEyes.....	17
3.1.6.	AIRA.....	18
3.1.7.	CampusBird.....	18
3.1.8.	Mobi Free	18
3.1.9.	iGlasses.....	19
3.1.10.	LaserCane™.....	21
3.2.	Relevant Technologies.....	22
3.2.1.	Amplitude Modulation Continuous Light.....	22
3.2.2.	Ultrasonic.....	23
3.2.3.	Pulsed Time-of-Flight.....	23
3.2.4.	Frequency Modulation of Continuous Wave.....	24
3.2.5.	Laser Interferometry.....	25
3.2.6.	Laser Triangulation.....	26
3.2.7.	Flash Lidar.....	33
3.3.	Strategic Components and Parts Selection.....	36
3.3.1.	Transmitters.....	37
3.3.1.1.	LEDs.....	37
3.3.1.2.	Lasers.....	37
3.3.2.	Receivers.....	39

3.3.2.1.	SNR.....	42
3.3.2.2.	Sensitivity and Spectrum.....	42
3.3.2.3.	Detectors: CMOS vs. CCD vs. PSD.....	44
3.3.3.	Optics Lens Selection.....	45
3.3.3.1.	Spot Size.....	46
3.3.3.2.	Divergence.....	47
3.3.4.	Bandpass Filters and Filtering.....	55
3.3.5.	Timing.....	60
3.3.6.	Microcontroller.....	60
3.3.7.	Power Source.....	64
3.4.	Purchased Components.....	66
4.	Related Standards and Realistic Design Constraints.....	68
4.1.	Related Standards.....	68
4.1.1.	Laser Standards.....	69
4.1.2.	Design Impact of Laser Standard.....	70
4.1.3.	Software Standards.....	71
4.2.	Realistic Design Constraints.....	72
4.2.1.	Economic and Time Constraints.....	73
4.2.2.	Environmental, Social, and Political Constraints.....	74
4.2.3.	Ethical, Health & Safety Constraints.....	75
4.2.4.	Manufacturability and Sustainability Constraints.....	75
5.	Projected Hardware Details.....	77
5.1.	Initial Design and Architectures and Related Diagrams.....	77
5.2.	Laser Transmitter.....	79
5.2.1.	Power Considerations.....	79
5.2.2.	Diode Driver.....	81
5.3.	Optical Configurations.....	83
5.3.1.	LIDAR, Electronic t_0	83
5.3.2.	LIDAR, Optical t_0	84
5.3.3.	Laser Triangulation.....	88
5.4.	Receiver Signal Processing.....	90
5.4.1.	FPGA Array.....	90
5.4.2.	Analog-To-Digital Conversion.....	90
5.4.3.	Time-To-Digital Conversion.....	93
5.5.	Power Supply.....	93
5.5.1.	Battery Technology.....	94
5.5.2.	Lithium Ion Battery Safety.....	95
5.5.3.	Battery Protection Circuits.....	96
5.6.	PCB Design.....	97
5.7.	Haptic Feedback Devices.....	98
5.7.1.	Haptic Driver.....	98

5.7.2.	Haptic Actuator.....	98
6.	Projected Software Details.....	100
6.1.	Development.....	100
6.2.	Survey.....	101
6.3.	GPS.....	102
6.3.1.	Compass.....	102
6.4.	Interrupts vs. Polling.....	103
6.5.	Low-Power Modes.....	104
6.6.	Programming Language.....	105
7.	Project Testing and Prototype Construction.....	107
7.1.	Hardware Test Environment.....	107
7.1.1.	CNC Machining vs 3D Printing.....	107
7.1.2.	Optical Housing	108
7.2.	Hardware Specific Testing.....	110
7.2.1.	Laser Transmitter Characterization.....	110
7.2.2.	Spectrum.....	115
7.2.3.	Bandpass Filter Testing.....	115
7.2.4.	Laser Triangulation System Testing.....	116
7.3.	Software Testing Environment.....	117
8.	Administrative Content.....	118
8.1.	Milestone Discussion.....	118
8.2.	Budget and Finance Discussion.....	120
8.3.	Project Design Problems.....	121
8.4.	Looking Forward.....	122

Appendices

- I. Appendix A - Copyright Permissions
- II. Appendix B - Datasheets Appendix
- III. Appendix C - Works Cited

List of Figures

Figure 1: House of Quality.....	11
Figure 2: Hardware Responsibilities Block Diagram.....	12
Figure 3: Ultracane.....	15
Figure 4: WeWalk Features.....	16
Figure 5: MobiFree Prototype Devices.....	19
Figure 6: iGlasses Viewing Radius.....	20
Figure 7: LaserCane™ Detection Description.....	21

Figure 8: Phase Shift for Amplitude Modulation of Continuous Light.....	22
Figure 9: Time-of-Flight System.....	24
Figure 10: Frequency Modulation System.....	25
Figure 11: Michelson Interferometer.....	26
Figure 12: Laser Triangulation System Geometry.....	27
Figure 13: Specular and Diffuse Reflection.....	28
Figure 14: Spot Size.....	29
Figure 15: Commercial Laser Triangulation Design.....	30
Figure 16: Computer Vision Laser Triangulation.....	31
Figure 17: Laser Triangulation Design.....	32
Figure 18: Flash LIDAR.....	34
Figure 19: Signal-to-Noise Ratio.....	41
Figure 20: Material, Bandgap Energy, Cutoff Wavelength.....	43
Figure 21: Wavelength vs Responsivity.....	43
Figure 22: Detector Responsivity.....	45
Figure 23: Collimation of Laser Beam using Cylindrical Lens and Asphere.....	48
Figure 24: Collimation using Two Plano-Convex Cylindrical Lenses X View.....	49
Figure 25: Collimation using Two Plano-Convex Cylindrical Lenses Y View.....	49
Figure 26: Spot Diagram in the X-Dimension.....	50
Figure 27: Spot Diagram in the Y-Dimension.....	50
Figure 28: Physical Optics Propagation #1.....	51
Figure 29: Physical Optics Propagation #2.....	51
Figure 30: Cylindrical Lens Collimation X Dimension.....	52
Figure 31: Cylindrical Lens Profile X Dimension.....	53
Figure 32: Cylindrical Lens Collimation X Dimension.....	53
Figure 33: Cylindrical Lens Profile Y Dimension.....	54
Figure 34: Yellow Phosphor Fluorescent Lamp Spectrum.....	56
Figure 35: Mercury Vapor Lamp Spectrum.....	56
Figure 36: Solar Spectrum.....	57
Figure 37: Diffraction Gratings.....	59
Figure 38: ATmega328P on an Arduino Uno.....	61
Figure 39: PIC24FJ128GC010 Microcontroller.....	62
Figure 40: MSP430F5529 LaunchPad.....	63
Figure : Purchased Major Components.....	66
Figure 41: MPE vs Wavelength.....	70
Figure 42: Eye Sensitivity Spectrum.....	71
Figure 43: System Block Diagram.....	77
Figure 44: Software Flow Block Diagram.....	78
Figure 45: Optics Flow Block Diagram.....	78
Figure 46: Electronics Block Diagram.....	79
Figure 47: 250 ms Exposure Energy Graph.....	80
Figure 48: Laser Exposure Energy and Power.....	81

Figure 49: LM317 Constant Current Laser Diode Driver Schematic.....	82
Figure 50: LIDAR (Electronic t0) System Diagram.....	83
Figure 51: LIDAR (Optical t0) System Diagram.....	86
Figure 52: Optical t0 Signal Pulses.....	87
Figure 53: Optical t0 Signal Concerns.....	87
Figure 54: Specular Reflection Method.....	89
Figure 55: Regular Reflection Model.....	90
Figure 56: Falling Edge Clock Detection.....	94
Figure 58: Linear Image Sensor Array Value Storage and Measurement.....	102
Figure 59: Polling vs Interrupts.....	105
Figure 60: Front Side View of Optical Housing.....	110
Figure 61: Right Side View of Optical Housing.....	110
Figure 62: Breadboard Testing of Laser Diode Driver.....	111
Figure 63: Current-Output Power for Thorlabs L904P010 905 nm Near Infrared Laser Diode.....	112
Figure 64: Optical Alignment for Collimation using Single Spherical Lens.....	113
Figure 65: Spot Size using Spherical Lens and Thorlabs L904P010 905 nm Near Infrared Laser Diode.....	114
Figure 66: Optical Alignment for Collimation using Two Plano-Convex Cylindrical Lenses.....	114
Figure 67: Spot Size using Plano-Convex Cylindrical Lenses and Thorlabs L904P010 905 nm Near Infrared Laser Diode.....	115
Figure 68: Optical Bandpass Filter for 905.....	117

List of Tables

Table 1: Marketing and Engineering Requirements.....	5
Table 2: Microcontroller Requirements.....	6
Table 3: Laser Triangulation Requirements.....	7
Table 4: Power Requirements.....	8
Table 5: User Interface Requirements.....	9
Table 6: Software Requirements.....	9
Table 7: Navigon Subscription Plans.....	17
Table 8: AIRA Subscription Plans.....	18
Table 9: Pro and Cons of LIDAR.....	34
Table 10: Pros and Cons of Ultrasonic.....	35
Table 11: Pros and Cons of Laser Triangulation.....	35
Table 12: Summary of Range Detection Techniques.....	36

v

Table 13: Comparison of NIR Laser Diodes.....	38
Table 14: Pros and Cons for Light Emitting Diodes.....	38
Table 15: Pros and Cons for Laser Diodes.....	38

Table 16: Optic Lens Evaluation.....	55
Table 17: Microcontroller Comparisons.....	64
Table 18: Chosen Hardware Components.....	67
Table 19: Laser Classifications.....	70
Table 20: Texas Instruments ADC Component Comparison Chart.....	92
Table 21: Maxim ADC Component Comparison Chart.....	93
Table 22: Variable-Mode Software Functionality.....	101
Table 23: Software Design Plan (V-model).....	102
Table 24: MSP430 Ultra Low Power Modes.....	106
Table 25: Senior Design 1 Milestones.....	119
Table 26: Senior Design 2 Milestones.....	120
Table 27: Budget and Finance Breakdown.....	121

1. Executive Summary

This paper is a comprehensive report documenting the totality of the research, planning, designing and testing of our product that we have created: HeadsUp. Our product is designed to be used by individuals who have total or near-total blindness who may benefit from our device's ability to provide haptic feedback to the wearer according to the proximity of objects in front of them. We hope that the provided information will be of great benefit to those with a fear of prematurely encountering objects at head-level and thereby preventing injury to the wearer.

In order to conduct research for our product, we set out to speak with local companies who have devoted time and energy to the aid of individuals with visual impairments and blindness. In addition to these conversations, we did research via online web searches and collegiate textbooks on relevant subject matter. For our project planning, our group met together on a weekly basis to discuss all matters of our design, assign tasks, and review our accomplishments. We also utilized online tools that allowed us to remotely reference our objectives and collaborate on any topics that required insight from multiple team members. The results of our research and planning allowed us to design our prototype product. Using a cyclical process of both of these methods, we were able to compare and choose individual components and comprehensive products that would accomplish the functionality that we decided on implementing while still meeting our incontestable restrictions (as written out in our *Engineering Requirements* section). Our last step, testing, was accomplished primarily on the campus of The University of Central Florida (UCF). For our projects, all students participating in senior design were given access to lab space with equipment that allowed us to prototype and test our components.

Throughout this document, you may read about the heart behind this project: to provide individuals with a greater range of independence and autonomy by using modern optical and electronic technology to productively harness the complex properties of light. You may also read about our research findings and subsequent design choices for our device, as well as the many mathematical considerations that were made when choosing the methods and components that will be utilized in our product.

As currently designed, our device is able to provide all of the primary functionality that we desired for it to accomplish. It's users will be able to be notified of any encroaching objects at head level with fast response times and will be able to control how and when they receive these responses. Not only will they have a long duration of usability, but they will also be able to know when they need to charge their device again before it dies. We hope that the

forethought in all of our design decisions will give users great satisfaction in using our device.

While we are very proud of all that this device is able to provide its wearers, we were unfortunately unable to implement all of the supplementary features that we had hoped would be additionally helpful. Some of these include the ability to communicate with smart devices such as smartphones, GPS capabilities that would help the user navigate unknown areas, and a smaller, sleeker packaging for the user to fit on the frames of their eyeglasses. With more time and resources, these could be implemented in future versions of this device.

Our team took great care to review and follow the engineering design standards that are applicable to our product in its development. You can read about these and why we needed to adhere to them in the *Standards* section of this document. We sought to follow all regulations in regards to all of the encompassing areas that engineering products affect.

Thank you for taking the time to read this paper. It is our desire that this report and our product are both able to promote inspiration, creativity, imagination, confidence and hope.

2. Project Description

The project section description outlines the motivation and goals for the project to develop a visual aid to support and help visually impaired people navigate their surroundings. The project was taken on as a challenge to utilize the team's knowledge, strength, and engineering abilities to create a meaningful product. The project was undertaken with the help and guidance of our faculty advisors, Dr. David Hagan, Dr. Samuel Richie, and Dr. Lei Wei, UCF Student Accessibility Services and Lighthouse of Central Florida. The authors would also like to thank Dr. Weed, Dr. Soileau, and Dr. Piracha for the time given to brainstorm and discuss their technical expertise. These organizations and individuals have greatly influenced the design and end product by giving the group members information on orientation and mobility of visually impaired people. Without the insights given by these organizations and these individuals, the scope of the project would not be able to be narrowed. The conversations have shaped and ultimately defined the engineering and marketing requirements for the device which will be used by the visually impaired.

2.1 Project Background

Every day, we rely on our senses to give us information about our surroundings. Sight is one of the senses that provides us the most information about our surroundings. Whether it be textures on the ground, terrain changes, objects in our path, locations or landmarks to identify, and cars driving by, our sight provides to us information we otherwise would not as easily notice. Without reliable eyes, it would be very difficult to walk freely and safely anywhere. The majority of humans can wake up everyday and never have to worry about accidentally bumping into a tree on their way to work (that is, of course, that said individuals are not distracted by certain mobile devices) But this is not the case for everybody. According to a study conducted by the World Health Organization in 2017, 39 million people around the world suffer from blindness. {Organization, 2010 #1} The national federation for the blind states 1.1 million of these 39 million blind people live here in the United States and 50,000 more new cases of blind people emerge every single year in the United States. {Moran, 2003 #8}

Blind and visually impaired people face a challenge everyday navigating their environments. The supply and demand for a product or solution is evident.

Cities in particular were designed by people with vision for people with vision. Just notice the billboards, street signs, crosswalks, and building identification markers. While our project cannot necessarily implement large changes to cities to make them more accessible and safe for people who are vision impaired, we can develop an aid to better help them navigate their surroundings.

Our solution is an innovative device that we call HeadsUp. The reason why we chose to do this project is because we do not believe blindness should create unnatural barriers that prevent people from achieving a full and successful life in society. The advancement of technology should be leveraged today so that people who are blind can integrate naturally into the lives that are lived by those around them. We want to empower blind people to be able to move with confidence regardless of their surroundings, whether walking downtown or hiking in a forest.

The conventional walking cane is a powerful tool for blind people, providing instantaneous tactile feedback and information regarding the user's immediate whereabouts. This allows a blind person to determine where it is safe for them to plant their feet and move forward, as well as to detect objects, walls, and elevation changes as they approach. The challenge with the walking cane is the limited range to detect potential obstacle hazards and relay this information back to the user. Standard white canes range in size generally between 110 cm - 150 cm. Past this range, the white cane does not provide environmental information to the user whatsoever, and the user is left with only their other senses and potential assistance from others to guide their way. As such, the solution we propose is a device that would provide additional ranged information to a blind user.

2.2 Objectives

We are seeking to develop HeadsUp to be a device that would both extend the obstacle and hazard detection of a conventional walking cane as well as provide users with additional information regarding potential obstacles at mid-to-head height, which conventional walking canes entirely lack. Such a device will allow for the user to better plan their path and avoid obstacles, such as walls, tree branches, bars, and counters. This solution would be packaged in a location that is not cumbersome for the user: their head. As a head mounted device, the device would allow for users to keep a familiar, useful tool in the form of the white cane while also gathering more environmental information to use as a supplement to the tactile information gained from the cane. The user then has the option to use their hands for various tasks while not being encumbered by another handheld device. In fact, if the user so wishes, he or she may use the HeadsUp device as a standalone aid. Our head-mounted design leverages the sophisticated and natural motions of the user's head and neck to scan their environment and direct the use of the device.

While there are a few aids that have been developed for the blind, mostly in the form of modified white canes that provide additional sensory information, they are prohibitively expensive for your average person. Additionally, adding features and changing the natural responses of a tool that a user is already familiar and

adept with may prove difficult for them to adapt to and reduce the overall effectiveness of the device during the learning period. By producing an optically based solution that is head-mounted, we hope to provide a solution that is both cost-effective and serves as a supplementary information gathering and navigation planning tool for the blind.

2.3 Requirements Specifications

In the following table and also in the House of Quality diagram (see Figure 3), we have specified this project’s design constraints, constraint justifications, and constraint effects. In the process of further researching and refining our designs, we intend to meet at least the following criterion:

Table 1: Marketing and Engineering Requirements

Category	Spec/Constraint	Justification
Detection Distance	Less than 2 meters.	The user should be aware of obstacles undetected by a walking cane.
Connectivity of Electronics	Less than 2 meters.	Effective connectivity in close proximity given power, form factor, and price constraints.
Operational Input	Intuitive and non-complex user input.	Interfacing that is not intuitive or simple for a visually impaired user may become frustrating.
Size	Small interface device(s) with peripherals (power source/etc) that can be held elsewhere by mechanical mechanism (bag/clip/etc.)	Able to be worn/carried by a human with minimal interference to everyday activities.
Weight	Less than 5 lbs.	Able to be worn/carried by a human with minimal interference to everyday activities.
Operation Time	1-12 hours	The device should have enough energy for a typical day’s use.

Feedback Response Time	Less than 1 second	The user should be given enough time to react to an approaching object.
------------------------	--------------------	---

2.3.1 Hardware

The most salient constraint of this project is certainly the size of our system. If we are to adapt it to a head-mounted system, then the packaging for our PCB and optical system has to be very compact and placed strategically in locations on the general user. Some of the locations we considered were on the eyeglasses and on the head. As the front of the glasses may not be used for vision, it was possible to place certain components, such as light detectors or emitters, on the lenses themselves, and connect power and computation from a secondary location on the person. The head may also be a good location with the optics, and potentially computational and power electronics, mounted on a hat or headlamp strap. More research on this will be covered in future chapters.

2.3.1.1 Microcontroller

The microcontroller is the central brains of the project that will handle all of the power management, sensor interpretation, and feedback provision. The following table provides some of the key features that we require the microcontroller to possess:

Table 2: Microcontroller Requirements

	Requirement	Justification
1	Be powered by less than 12v	Most battery packs output this voltage.
2	Have low-power mode	Our electronics need to last as many hours as possible.
3	Be fast enough to provide quick feedback to user	Slow electronic response times could lead to slow physical response times (which may be harmful to the user).
4	Be capable of Digital-to-Analog and Digital-to-Analog conversions	The analog optics need to be read by the digital microcontroller which needs to give analog feedback
6	Understand when battery levels	We want the user to have a good

	are low	understanding of the remaining time to use the device
--	---------	---

2.3.1.2 Laser Transmitter and Receiver

The laser transmitter and receiver requirements are used to define the technical requirements of the laser triangulation system. The performance and project goals are closely intertwined on the execution of these requirements.

Table 3: Laser Triangulation Requirements

	Requirement	Justification
1	Laser Detection Speed Less than 250ms.{, 2018 #9}	Feedback should be given with enough time for the user to respond.
2	CMOS Infrared Spectral Response	Efficiency of converting light to electrical energy
3	Laser Beam Size Diameter = 1mm	Allows high intensity to be diffusely reflected and imaged onto CMOS
4	Laser Pulsed	Eye-Safety Higher Peak Power
5	Laser Wavelength ($\lambda = 905 \text{ nm}$)	Safe for human eyes and effective for detection. Visible wavelengths are strongly absorbed by the eye. Cost effective emitters/detectors
6	Laser Output Power ($P_{\text{out}} = 2\text{mW}$)	Effective and minimal power output.
7	Resolution 1 ns / 6 inches	Distinguish two points
8	Detector Sensitivity = 7 nW	What this means in laser power at a distance of 1m is the ability to detect a reading.
9	Receiver Area = 10 mm X 10 mm	Large area allows large working range to detect objects

2.3.1.3 Power Source

Our design requires a portable power source which can last up to 12 hours on a single charge and does not add a significant amount of weight or size to our product. This makes the rechargeable lithium ion battery an attractive choice of power source due to its high energy density, providing sufficient charge for the operation of our diode, microcontroller, and other electronics within a compact form factor. The lithium ion battery has the additional advantage of a low self-discharge rate relative to other battery chemistries, as well as not requiring any priming or maintenance in order to function properly. However, lithium ion batteries are also more costly than alternative battery technologies, and they require additional circuitry to ensure that they maintain operation within safe limits. Fortunately, the cost difference between lithium ion and alternative battery technologies are not excessive and the safeguards necessary to prevent over-charging and -discharging can be incorporated into our design without great difficulty.

Table 4: Power Requirements

	Requirement	Justification
1	Provide 1-12 V	Sufficient to power microcontroller and laser
2	Operation time of 1-12 hours per charge	Should last long enough for a typical day of use without needing to be recharged
3	100 mA constant current to diode	Constant current of 100 mA to ensure steady diode operation
4	Compact and lightweight	Should not add significantly to the weight and dimensions of our design

2.3.1.4 User Interface

Because this device will be used without visual aid, this device will utilize the strengths of two other senses: sound and touch. Contained in the table below are some requirements and justifications for features that should be implemented in order to make this goal possible.

Table 5: User Interface Requirements

	Requirement	Justification
1	Few buttons, switches, etc.	Reducing complexity of design
2	Audio cues	For interfacing with any in-depth interaction
3	Haptic feedback	Primary feedback mechanism
4	Intuitive setup	Ease of use; minimizing frustration
5	Power feedback	Notify the user of the device running low on power
6	Speedy startup	The user should not wait a long time for the device to power on

2.3.2 Software

The software will consist of a program ported to the microcontroller using Code Composer Studio. Texas Instruments provides developers their CCS software and microcontroller libraries that will allow us to include the necessary functionality. Requirements for the software are included in the table below.

Table 6: Software Requirements

	Requirement	Justification
1	Must run on a small processor	Equipment size should be kept to a minimal
2	Should be lightweight if possible	Short of writing entirely in assembly, we want to write fast processing code in order to provide timely feedback
3	Will control reading sensor signals	Receive and store necessary information from the optical receiver
4	Will control emitting sensor signals	Analyze and give feedback to information received via user feedback devices (audio/haptic)

5	Will control converting signals from/to Analog/Digital as the case may be	Receiving and emitting signals will be analog while processing signals will be digital
6	Should not take a long time to start up the device	User interfacing should be intuitive and convenient
7	Should be as small as possible	Must leave enough onboard memory for program running/ data storage

2.4 House of Quality Analysis

The most important engineering requirement targets for our design are a weight of less than five pounds and compact physical dimensions, detection distance of between two and five meters, battery life of twelve hours, and microprocessor speed on the order of 1 GHz, at a cost of less than \$300.

We want to minimize the weight of our design, since a heavy product will decrease comfort for our users. This consideration is closely linked to the dimensions of our design, which we also seek to minimize. The main trade-off for reducing weight will be an increase in cost, since it will require us to utilize more compact components and form factors, which will be more expensive than larger alternatives with similar performance characteristics. In addition to using a compact design, we will also opt for low-density material wherever possible to bring down the overall weight of our product.

The detection distance can be improved by choosing an appropriate laser wavelength and output power, thereby giving us better range and reliability. The tradeoff for achieving ideal detection distance will be an increased cost as well as less favorable battery life and dimensions.

The battery life of twelve hours will ensure that the device lasts for a typical day of use on a single charge, thereby increasing reliability. In order to achieve this battery life, cost will be increased in order to afford sufficient battery capacity and laser output power and processing speed will be controlled to achieve balanced power usage. Cost considerations and our choice of rechargeable lithium ion battery technology as a power source are considered in further detail in future sections.

Our choice of a microprocessor should allow us to provide our users with accurate and reliable sensory feedback at a rate that is compatible with their reaction times, which is reflected in the proportional relation between processor speed and reliability. In addition to running calculations for range detection, the microprocessor may also interface with a Global Positioning System module in

order to further increase our system’s reliability by provide accurate directions to set locations. The major trade-off for microprocessor speed will be battery life, since a more powerful processor will drain our system’s power supply more quickly. This can be balanced by using the microprocessor to sense when our battery is running low and by incorporating a low-power mode that limits power draw in order to extend battery life.

Below is our house of quality diagram, which provides a visual representation of the trade-offs between our engineering requirement targets and relevant design considerations.

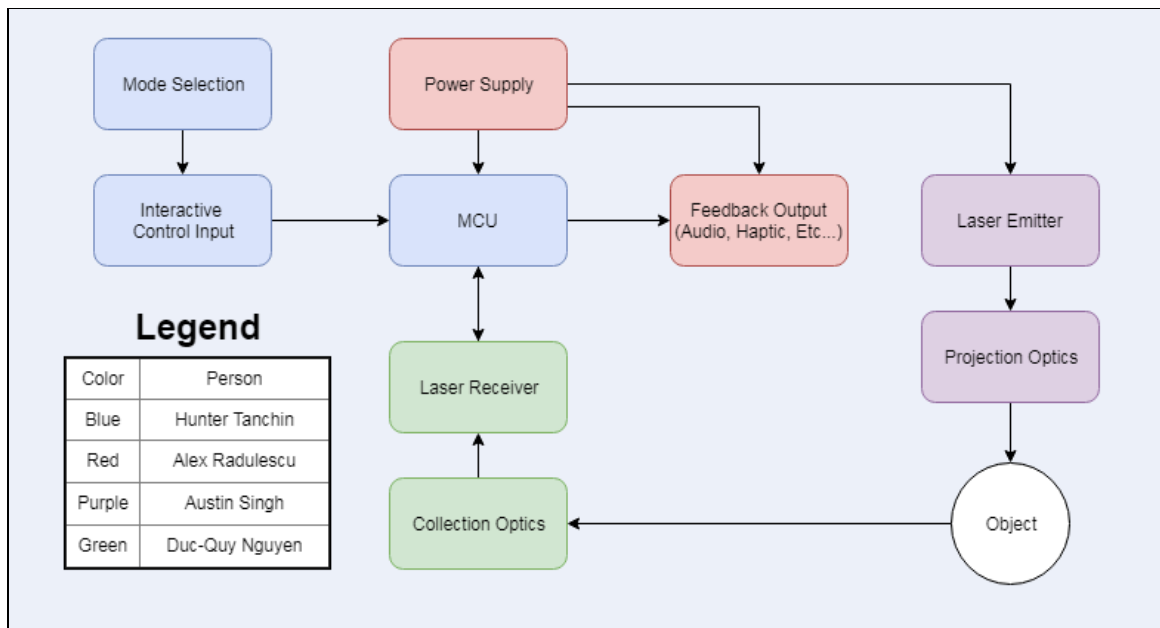
Figure 1: House of Quality (Permission not needed)

	Detection Distance (+)	Processing Speed (+)	Laser Wavelength (nm)	Laser Output Power	Battery Life (+)	Dimensions (-)	Weight (-)	Cost (-)
Range (+)	↑		↑	↑		↓	↓	↓
Comfort (+)						↓	↓	↓
Reliability (+)	↑	↑	↑		↑			↓
Cost (-)	↓	↓	↓	↓	↓	↓	↓	↑
Targets for Engineering Requirements	1-2 m	25 MHz	905 nm	2 mW	8-12 hours	55-65 mm	< 5 lbs	\$285

2.5 Project Responsibilities

We created the following block diagram to give a general overview of the major moving parts within the project. Each box is color-coded based to indicate which individual is responsible for the functionality of that respective component. The arrows indicate the relationship between components. A single arrow means a way connection such as power supply providing power to the laser. The double arrow for example from the microcontroller to the computer indicate that our image is sent from our microcontroller to our computer to be analyzed. Once our computer has analyzed the image, a response is sent back to the microcontroller to give an appropriate response to the feedback output.

Figure 2: Hardware Responsibilities Block Diagram (Permission not needed)



The following tasks are what each group member will be responsible for the successful execution of our project to develop a visual aid tool to help visually impaired people navigate their environment:

- Laser Diode & Image Sensor: Austin & Quy
 - Responsible for the research and integration of the laser diode and the image sensor.
- Optical Design: Austin & Quy
 - Responsible for the research, lens selection, zemax simulations, and integration of projection Optics for laser diode as well as collection Optics for image sensor.
- Opto-mechanical Design: Quy

- Responsible for the design, fabrication, testing, and implementation of the 3D printed housing to keep laser triangulation fixed/stable from mechanical vibrations.
- Microcontroller: Hunter
 - Responsible for the open source software implementation to manage laser operations, the operation of user feedback devices, and the collection and processing of the data from the image sensor.
- Power Supply: Alex
 - Responsible for research and integration of power supply and proper power distribution to all components of the device.
- Circuit Design: Alex
 - Responsible for research and integration of feedback mechanism for visually impaired person (audio, haptic, etc...) as well as laser diode driver and pulsing.
- PCB: Alex & Hunter
 - Responsible for researching, design, ordering, soldering, testing, and implementing the PCB design for the computation electronics of the device.
- Packaging: Group
 - Responsible for collaborative research and design on how the entire system will be contained into a final unit with attention to project requirements, such as; price, weight, and size.

3. Research Related to Projection Definition

The research in this section begins with a comprehensive review of all the current products that exist in the marketplace to help the visually impaired navigate their environment. Following this section, the different techniques for object detection were evaluated to select which one would meet the specifications outlined earlier. The later portion of this section explains why the core components in the project were selected and the associated technical data with those components. It can not be emphasized enough how important the research in this section will translate to the overall success and execution of the project to develop a visual aid to support the visually impaired to navigate their environment.

3.1 Existing Similar Projects and Products

Technology has been created to help the blind navigate their environment. The research shows that the many products currently exist whether it be attachment for the white cane or mobile applications leveraging computer vision and artificial intelligence. The design for these products vary greatly, but the challenge with many of these products are that they are often very expensive making them inaccessible to a large population that needs it. For example, mobile applications developed act as eye's for the user, but often charge subscription fees or pay as you go structure for object identification. The pay as you go can quickly add up if you consider how many objects we encounter in our daily lives. With the help of UCF student accessibility services and Central Florida Lighthouse, we were able to get a list of products that are currently being used by blind people around the world.

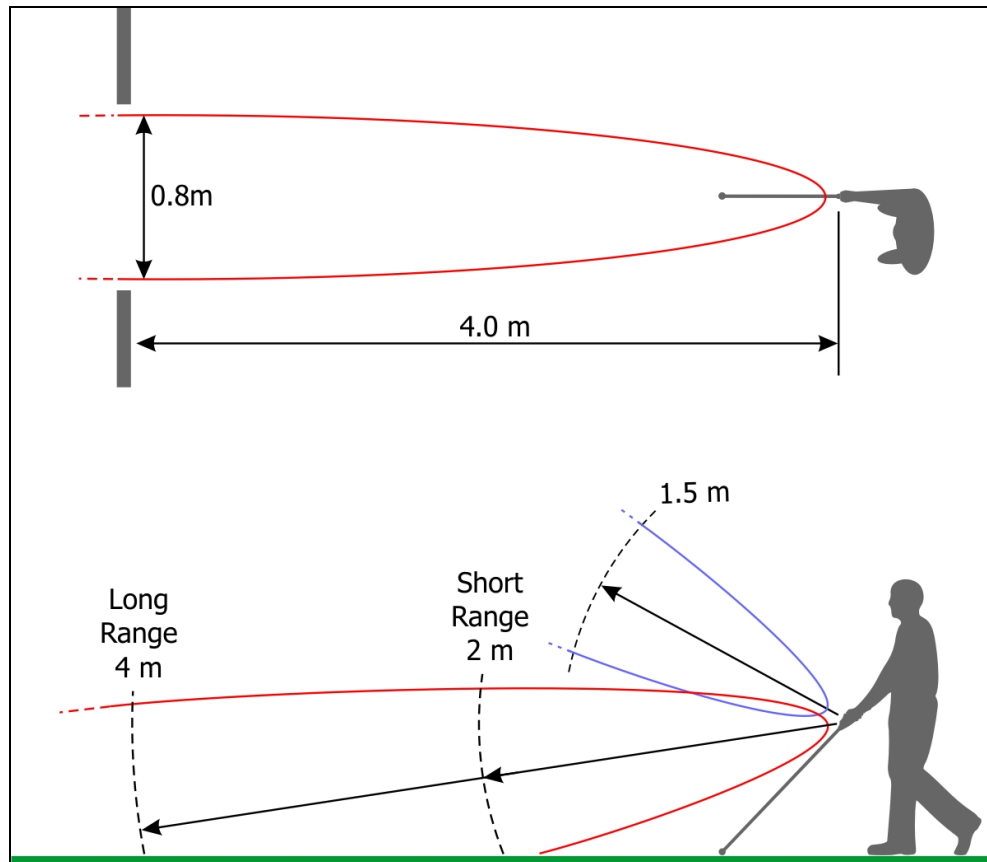
The main products Brad Held of UCF Accessibility and student services told us to explore include the Ultracane, WeWalk, BlindSquare, Navicon, BeMyEyes, AIRA, Campus Bird. MobiFree, and Ambutech.

3.1.1 Ultracane

The Ultracane is an electronic mobility aid used by blind or visually impaired people to avoid obstacles and navigate their surroundings. The main focus of the product is the ability to protect the head and chest from bumping into things. The technology used in the UltraCane is ultrasonic waves as can be seen in the figure below being emitted from sensors in the front. It is able to detect objects within two meters to four meters with a resolution of 0.8 meters. In the graphic it can also be seen that device has a 1.5 meter vertical detection zone as well. The button on the handle give haptic (touch) feedback to the user to indicate the direction the object was detected from. The price point for the Ultra cane is with

the carrying case is 650 euros or about \$74 US dollars. {, 2018 #10}

Figure 3: Ultracane Sensor Radius (Permission requested)

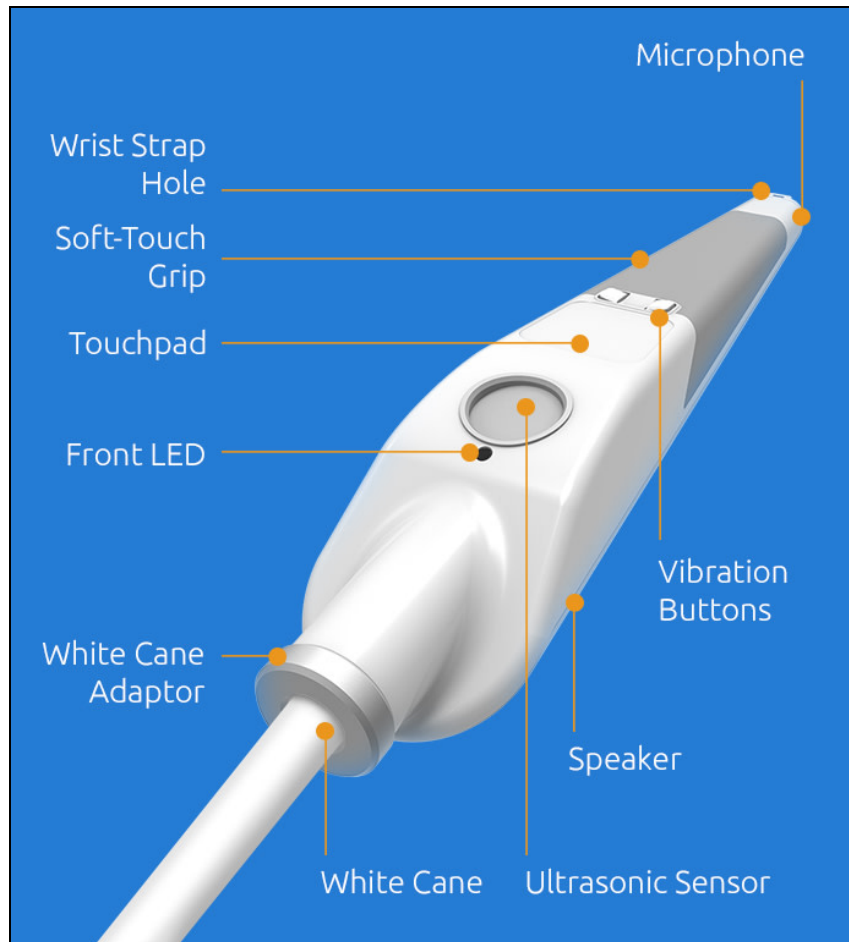


3.1.2 WeWalk

The WeWalk was developed in the United Kingdom by the Young Guru Academy which is a non-profit international organization. The product is an attachment that the user can fit onto their white cane and enables the cane to transform into a smart cane. The features that the WeWalk enable include detection of obstacles by using Ultrasonic Waves and haptic feedback via vibrations on the hand. The product while funded on kickstarter has yet to release a product so the technical specifications as maximum range that it can detect an object has not been disclosed. One thing that distinguishes this product from the Ultra Cane is the ability for smartphone integration. The WeWalk also uses a combination of audio and haptic feedback to alert the user. The device can give users instruction on how to move their environment and when they have arrived at their location using google map. The makers advertise that WeWalk enables blind or visually impaired people to have one free hand and this is critical to

allow users to feel more confident in their surroundings if they need to touch any objects. The price point for the WeWalk is approximately \$500. {, 2018 #3}

Figure 4: WeWalk Features (Permission requested)



3.1.3 Blindsquare

Blindsquare was developed as a GPS-application to help the blind and visually impaired to navigate the environment. The application uses sound to tell where users are and directions to their end location. The user is able to use their smartphone for cues of how to orientate themselves when they come to intersections. What is powerful about this application is that it stores knowledge of what street you are on so you don't have to constantly think about it. The cost of the application is \$40 in the apple store which makes it very competitive for what it offers. {, 2018 #2}

3.1.4 Navigon

Navigon is also a similar GPS-application that blind and visually impaired users can download to navigate their environment. What makes Navigon different than BlindSquare is it can be purchased as a stand alone unit for just that function. The software uses Global Positioning Satellites to determine your location and tell you how to move around. Navigon subscription prices are shown in the table below. {, 2018 #4}

Table 7: Navigon Subscription Plans

	North America	Europe	Australia/New Zealand
Monthly	\$4.99	\$4.99	\$4.99
Annually	\$29.99	\$29.99	\$25.99
Unlimited	\$59.99	\$79.99	\$49.99
Notes	<ul style="list-style-type: none">• Android based smartphones must be running Android OS 4.1 and up.• iPhone must be running iOS 10.0 or later.• Current Navigon Select users still supported but as of May 14, 2018 Navigon apps are no longer available for purchase or download		

3.1.5 BeMyEyes

BeMyEyes was developed by Hans Jørgen Wiberg. How the application works is it pairs blind and low vision people with normal sighted volunteers who help them see. The user holds their phone to capture video of what they are not sure is in front of them and the volunteer on the opposite end tells them what they are looking at. While this technology can be seen in Skype and Facetime, what makes this mobile application powerful is it can always connect you with somebody. With facetime and Skyping family and friends, you are at the mercy of whether or not they pick up your call. BeMyEyes is a powerful solution for the blind and it is completely free making it extremely accessible to people who have smartphones.{Wiberg, 2018 #11}

3.1.6 AIRA

AIRA was developed by Suman Kanuganti and Yuja Chang in conjunction with Google Glass. AIRA is similar to Be My Eyes except for the fact that the user has to buy a subscription allocating them a number of minutes with the visual interpreter in their day to day lives. The price point can be seen in figure below. The smart glasses have a camera in front of the nose and this allows operators to see the environment. What is unique about this approach to solve the problem of blind people navigating their environment is it is a hands free approach compared to having to hold your smartphone up and point at objects. The price of the subscription plan is difficult considering Be My Eyes is a free application providing theoretically the same service. {, 2018 #12}

Table 8: AIRA Subscription Plans

	Basic	Plus	Pro	Premium
Monthly Cost	\$89	\$129	\$199	\$329
Regular Minutes	100 minutes	200 minutes	400 minutes	Unlimited
All Plans Include	<ul style="list-style-type: none">● Austria Glasses● Data● Insurance for Hardware● Training Session● 24/7 Access to Agents			

3.1.7 CampusBird

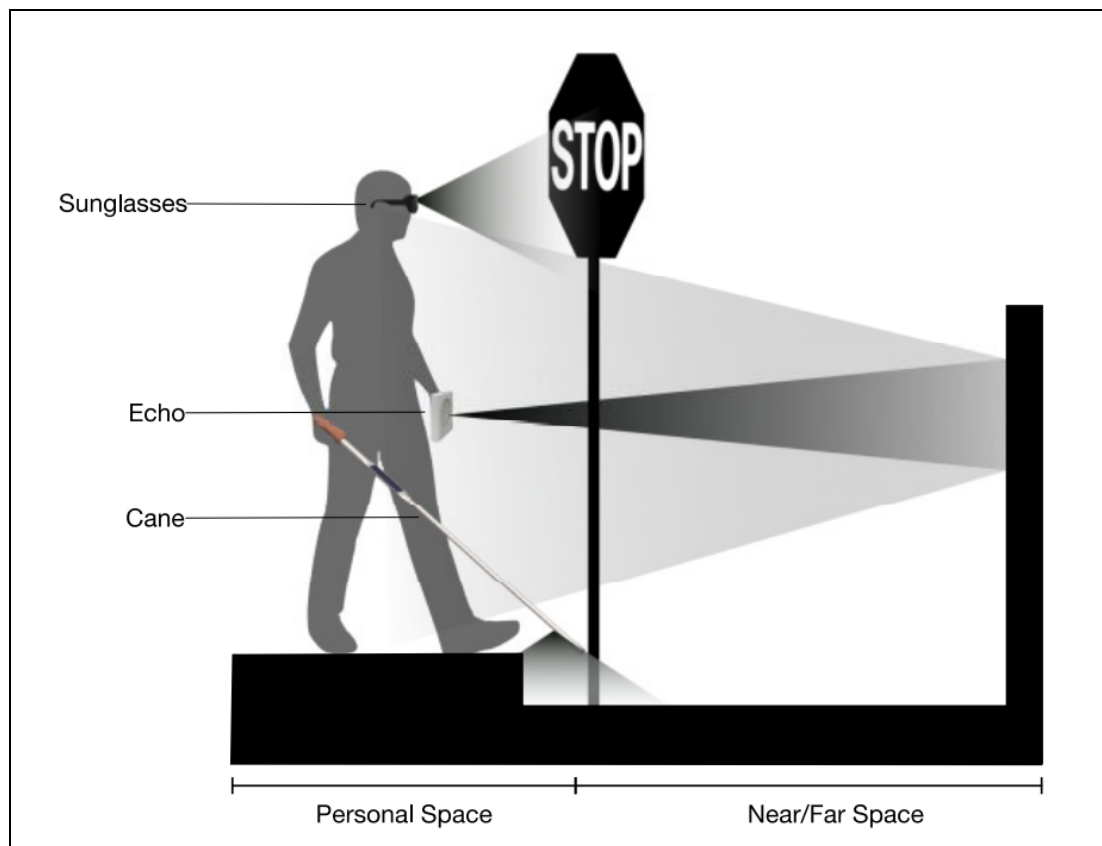
CampusBird is an mobile application that uses beacon mapping system on college campuses. As users walk to their location the mobile application will tell you audio cues as to where you are. What makes this different than other GPS based applications to help the blind and visually impaired navigate their environment is the accuracy and specificity of information relayed back to the user. The user is able to use CampusBird inside of buildings in which there are multiple floors. For a large campus, according to our sources, using CampusBird is cost prohibitive to provide the functionality everywhere. {, 2018 #13}

3.1.8 MobiFree

Mobifree is a prototype range detection system for the blind has been designed and implemented by a team at the University of Aveiro composed of three

devices utilizing ultrasonic emitters and receivers. While this system does provide benefits to its users, it requires the training and familiarization with two new pieces of technology as well as fundamentally altering the function of the standard white cane, perhaps the most critical mobility tool for the visually impaired, resulting in a system which is complex to learn. Additionally, the cost of this sensing habitat may be prohibitively expensive for potential visually impaired customers. {Sergio I. Lopes, 2012 #5}

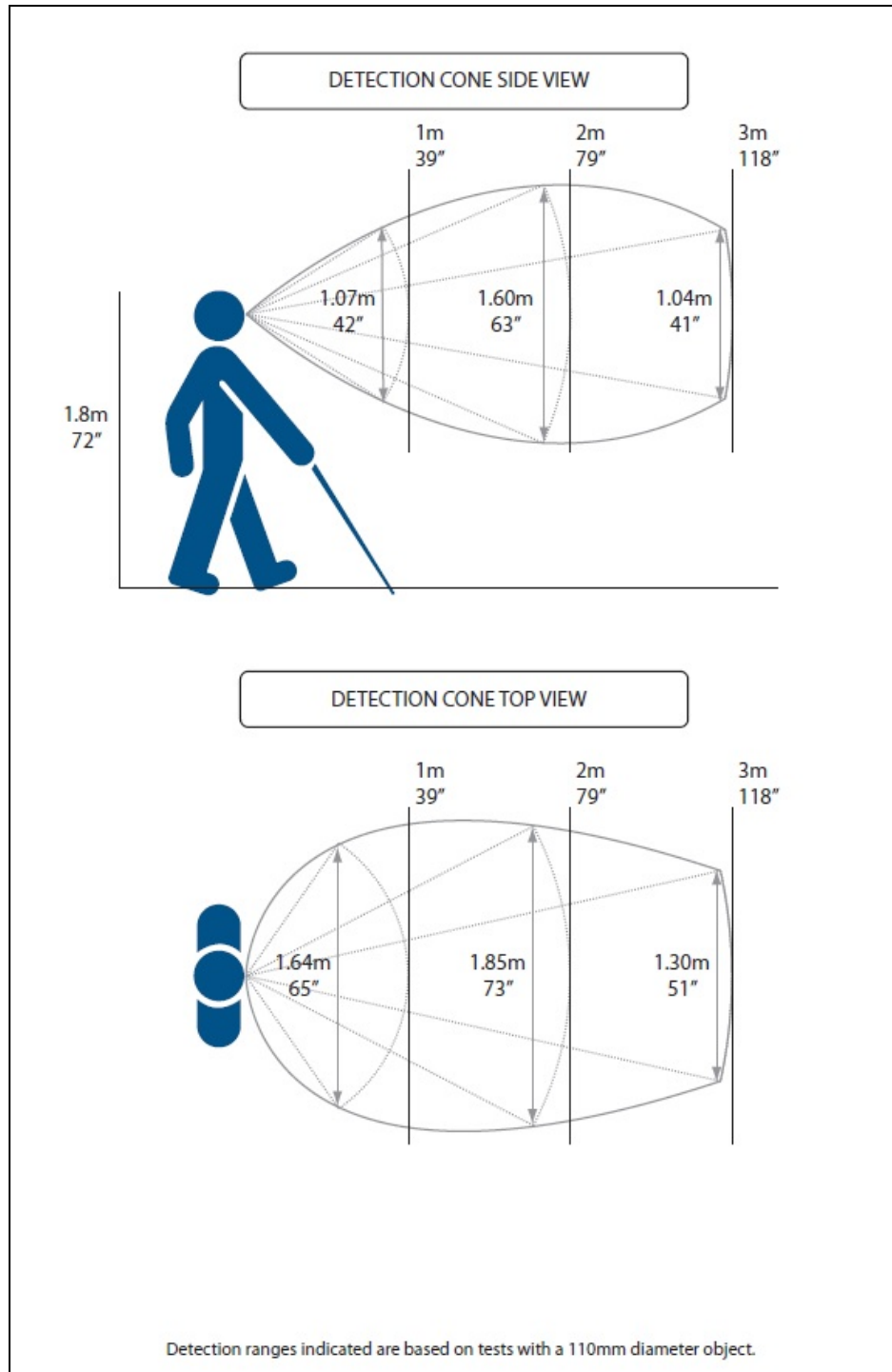
Figure 5: MobiFree Prototype Devices (Permission requested)



3.1.9 iGlasses

Ambutech has a product called iGlasses which is a head mounted ultrasonic mobility aid. The device has a detection range of zero to three meters and uses haptic feedback as user approaches a nearby object. The device can be custom fit onto your head and is lightweight. The price point for iGlasses is \$96.10 which makes it extremely affordable for users and competitive in the market. {, 2018 #14}

Figure 6: iGlasses Viewing Radius



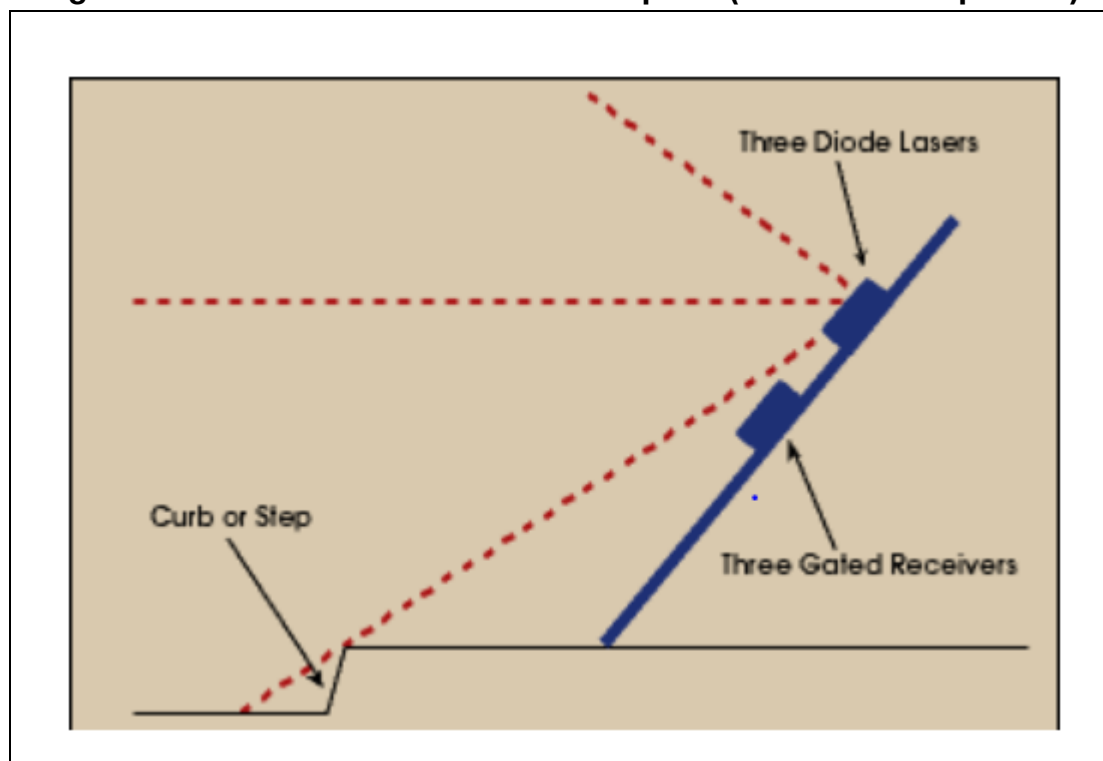
The market research done on the products that currently exist emphasize that the design of our product must incorporate haptic feedback and make sure the blind user does not stand out in a crowd. The glasses are powerful because it is ubiquitous. Audio feedback should not mask sound from the surroundings as

many blind and visually impaired users use this sound to make sense of their environment.

3.1.9 Laser Cane™

The LaserCane™ is a product engineered by Nazir Ali to help the visually impaired and veterans navigate their environment. What is unique about this product compared to the other products outlined in this section is the device has been approved by the United States Food and Drug Administration as a primary mobility device. The product is mainly able to detect overhangs, obstacles, and detect drop-offs in elevation. How the device works is it deploys three infrared laser diodes generating laser pulses pointed in different directions and three receivers which can be seen in the figure below. The drop off detection alarm is set off when the receiver does not receive any reflected light onto the detector or an “interrupt” occurs. The receiver is angled in a way to receive constant feedback from the downward faced laser diode. The laser diodes aimed forward and upwards detects objects when the incident light is reflected off the object. The feedback mechanism to the user is audible sound and tactile feedback on the side of the LaserCane™. While the laser cane provides great coverage of the surroundings to the visually impaired, the price point for the LaserCane™ begins at \$2,990 which makes it inaccessible to the majority of the population in need of such a product. {Hitz, 2003 #15}

Figure 7: LaserCane™ Detection Description (Permission requested)



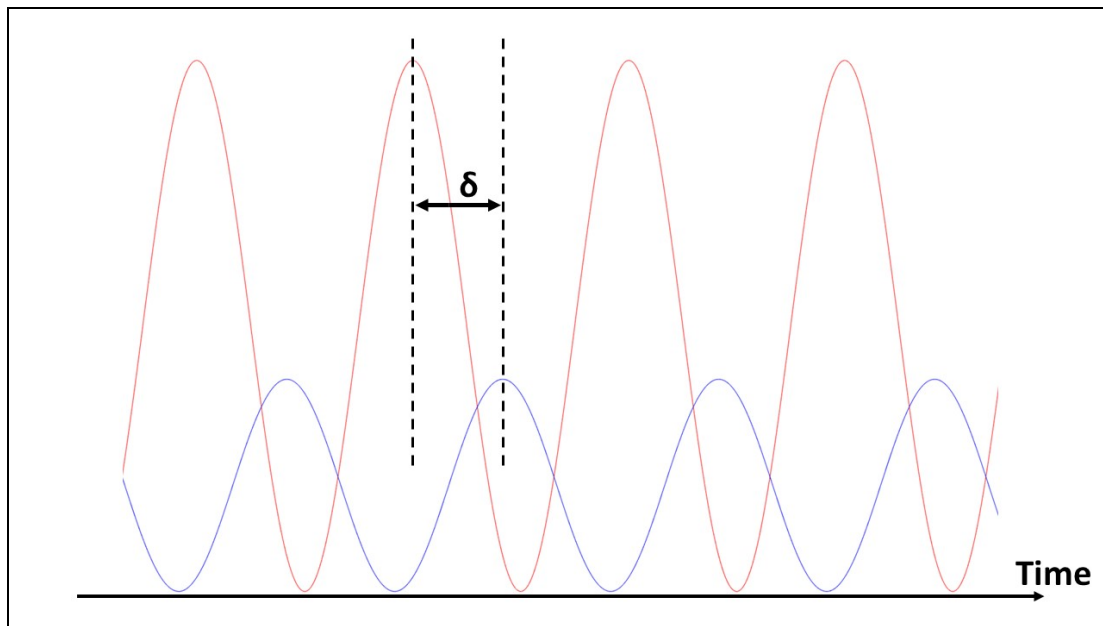
3.2 Relevant Technologies

The majority of methods to measure distance to an object include radio, ultrasonic, and optically. Often a signal is transmitted and the reflected signal is collected back and processed. The main difference between ultrasonic detection and light detection and ranging (LIDAR) is range capabilities and resolution. In the following section, we explore different methods to determine distance measurements to target objects as well as the associated pros and cons of the implementation. It can be seen that regardless of the design selected there exists tradeoffs in performance capabilities.

3.2.1 Amplitude Modulation of Continuous Light

Authors Berkovic and Shafir explain that amplitude modulation continuous light technique measures the phase shift between the launched and returned light. {Garry Berkovic, 2012 #6}

**Figure 8: Phase Shift for Amplitude Modulation of Continuous Light
(Permission not needed)**



The time of flight is derived from this information by dividing the phase shift by the modulation frequency. The equation can be seen below:

$$D = \frac{C}{4 * \pi * \omega} * \varphi$$

D represents distance, C represents the speed of light, ω represents modulation frequency, and ϕ represents phase shift. According to Berkovic and Shafir, this approach has the detection range of a few meters up to fifty meters. We have chosen not to use this technique due to the modulation rates required for our range specifications are very difficult to achieve. {Garry Berkovic, 2012 #6}

3.2.2 Ultrasonic Detection

A commonly used technology for range detection involves measuring the time of flight of ultrasonic waves. Electrical signals drive a device which emits ultrasonic acoustic waves, which then travel and reflect off of an object and are then measured by an ultrasonic wave detector, which converts the waves to an electrical signal. The time between the emitted and recorded signal and the distance to the reflecting object can be determined by the known speed of sound in air. These sensors can be found widely in many commercial sensing applications, from baby monitors to car parking sensors, offering cheap and effective solutions to these specific problems.

The most limiting factors of this detection method are the effective range and specificity of such a system. The means of generation and transmission of ultrasonic waves results in a wave which expands radially outward. Because of this, the signal power drops quadratically with distance, giving most ultrasonic detectors an effective range of two meters. Due to this radial emission, there is also a lack of specificity regarding the direction of detection. Although an object may be detected, there are few options for determining angular direction. The solution proposed in this paper is both effective at longer ranges and also allows for discernible direction based upon the orientation of the user.

3.2.3 Pulsed Time of Flight

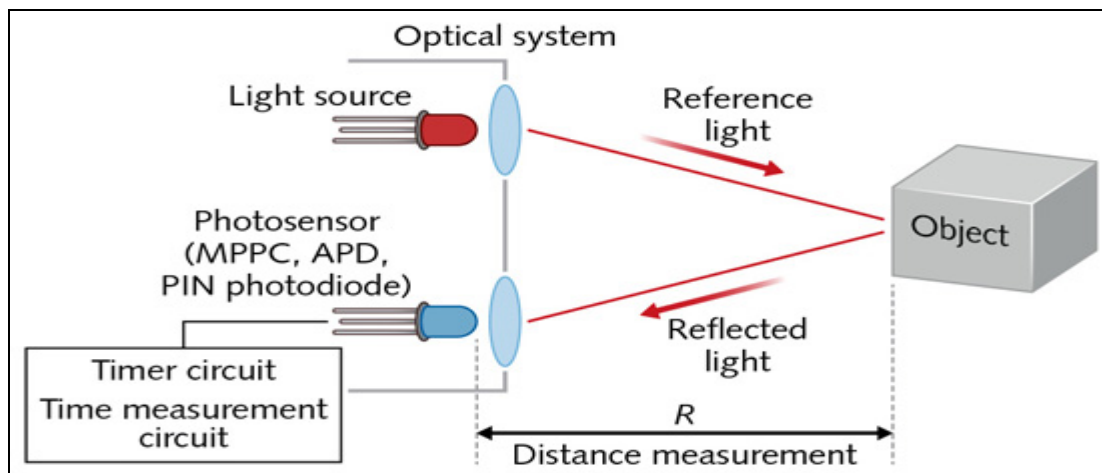
Laser pulse time-of-flight (TOF) distance measuring technique involves sending out a pulse of energy from a transmitter and then back to a receiver. The transmitter in most cases acts as the “start” and the receiver acts as the “stop”. Laser pulse time-of-flight essentially measures how long it took for light to travel a round trip. The equation that calculates this total distance traveled can be seen below:

$$2 * D = C * T$$

D represents distance, C represents the speed of light (which is approximately

$3 * 10^8$ meters per second), and T represents time (in seconds). The challenge of using laser pulse time-of-flight for absolute distance measurement lies in generating short pulses, timing electronics associated with it, and achieving a good signal to noise ratio (SNR). McAman states that LIDAR systems which need a detection range of beyond 1 meter typically require pulse widths of five nanoseconds to fifty nanoseconds. {Markus-Christian Amann, 2001 #7} Multiple commercial products currently exist for pulsed laser diodes as well as drivers. Furthermore, averaging multiple pulses we can improve the precision of our device. The timing electronics associated for laser pulse time-of-flight can be integrated using Texas Instrument modules. Laser pulse time-of-flight is more involved than other methods because it requires amplification circuits and more extensive digital signal processing. Despite all of this, laser pulse time-of-flight is a viable option to meet the requirements for our project as a range finder.

Figure 9: Time-of-Flight System (Permission requested)

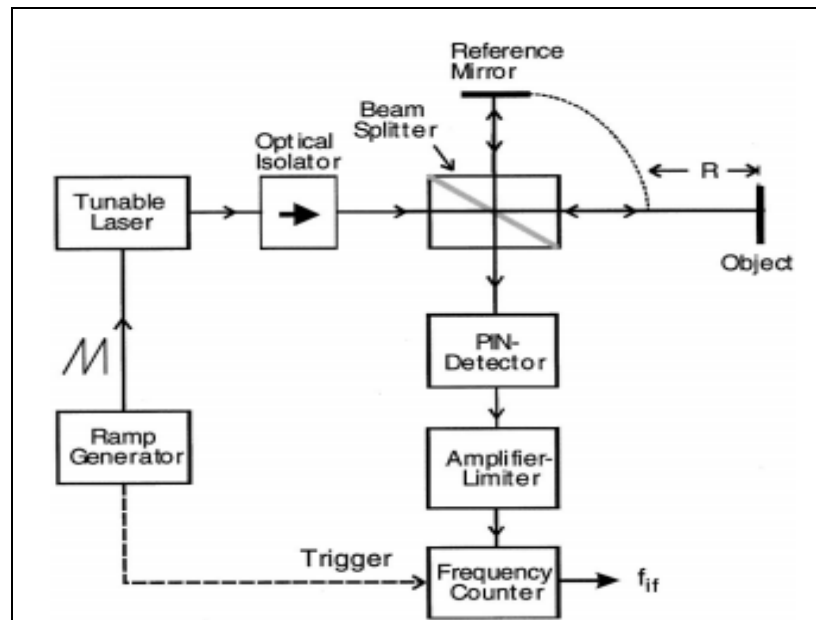


3.2.4 Frequency Modulation of Continuous Waves

In his paper on continuous wave frequency modulation, McAmann states that the frequency modulated continuous wave technique begins with an electronically tunable laser diode. {Markus-Christian Amann, 2001 #7} The laser output then passes through an optical isolator to maintain frequency purity as this can be impacted by reflections off the mirrors.. The laser output then becomes two beams with one traveling to the object and one traveling to the reference mirror. The reflected beams from the object and the reference mirror converge back at the PIN detector. Based on the instantaneous frequency which is periodically shifted by a set Δ frequency as probing/reference signal from the tunable laser diode, we are able to compared our reference signal and reflected

signal off our object. From this change in frequency we are able to calculate a time delay and thus determine a distance for our object. The advantage of frequency modulated continuous wave is no high speed electronics would be required to record the start and stop times. {Markus-Christian Amann, 2001 #7}

Figure 10: Frequency Modulation System (Permission requested)



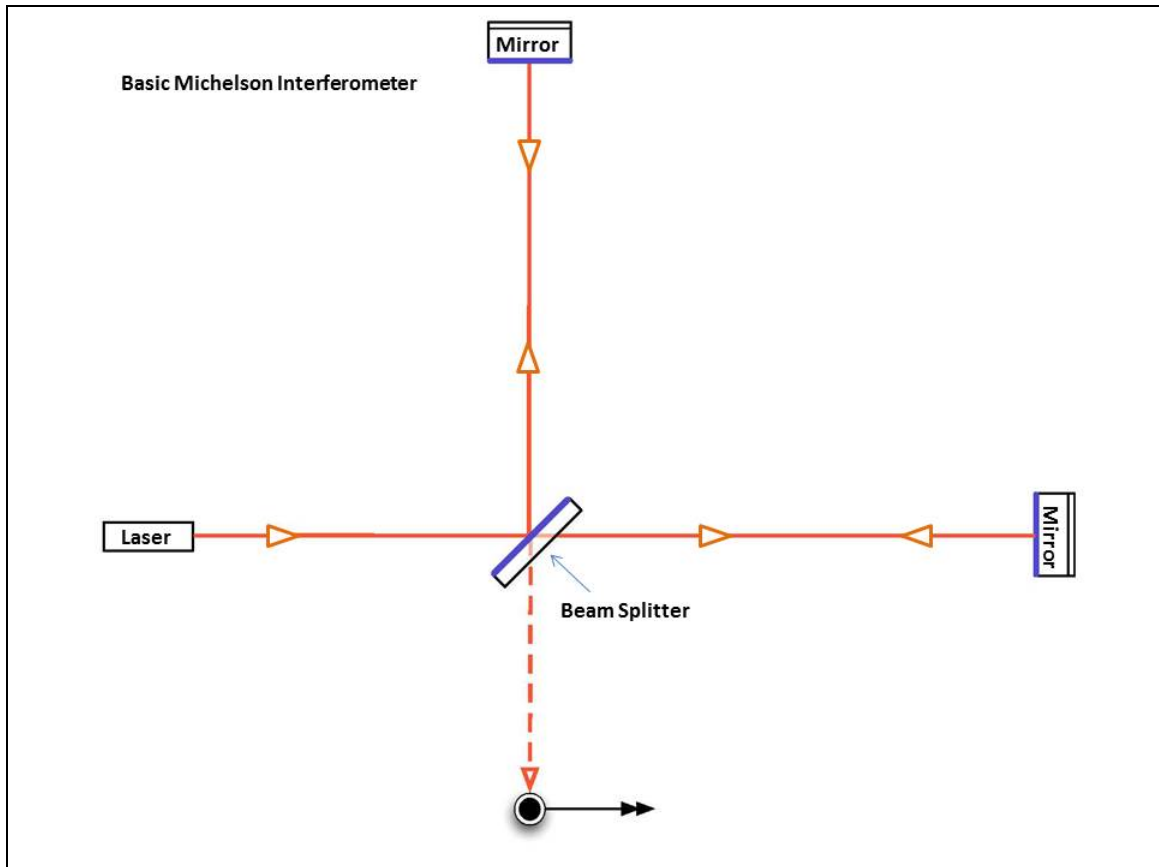
Frequency modulation continuous wave would work great, but based on the schematic shown above, it is not cheap. The main reason being the requirements to have a frequency modulated continuous wave system is to have an electronically tunable laser diode which can easily cost thousands of dollars. The tunable laser diode would also have to have a very narrow spectral linewidth. While the method has high performance capabilities, the individual components are very expensive which rules it out from our method of obstacle detection. In addition, it would be very difficult to integrate and implement so that our system meet our specification of portability. The budget and time constraints of our project rule out this method.

3.2.5 Laser Interferometry

Interferometry works by first light emitted from a laser is split into two laser beams by the beam splitter. Light travels to the respective mirror and is reflected back to the beam splitter. Light that is recombined can then interfere constructively or destructively. The interference pattern can be used to determine how much an arm length has changed if at all (physical distance). {, 2015 #16} Laser interferometry was used in the detection of gravitational waves and was able to detect changes on the scale of 1/10000th of the width of a proton. For

this reason, laser interferometry can be highly accurate and provide great resolution. However, laser interferometry would be very difficult to package and the costs of the individual components are very expensive which has ruled out this method.

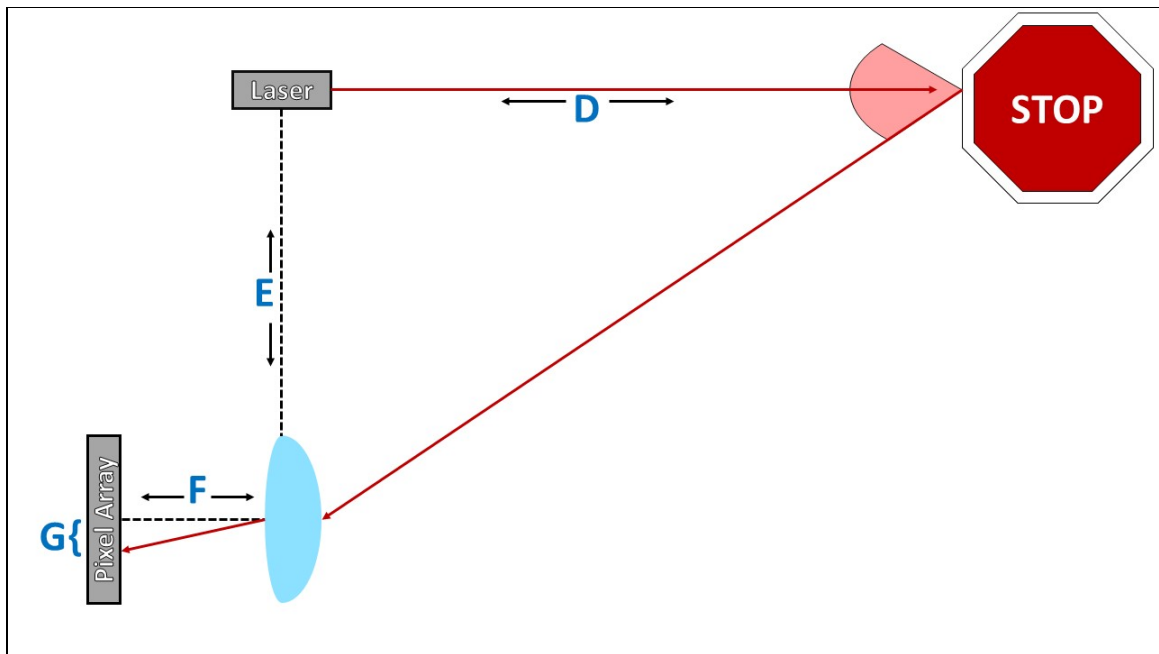
Figure 11: Michelson Interferometer (Permission requested)



3.2.6 Laser Triangulation

The laser triangulation method involves a transmitter typically a laser and a CMOS detector. The laser triangulation method is often used in manufacturing for non-contact measurements due to its ability to perform accurate and high precision distance measurements. How the laser triangulation technique works is a laser diode emits light that is collimated using a lens. The complementary metal oxide semiconductor (CMOS) element receives light reflected from a target object. By using the position of the laser spot on the CMOS detector in relationship to the center, the location of the measurement object is calculated. A geometric/mathematical representation of laser triangulation can be seen in the figure below.

Figure 12: Laser Triangulation System Geometry (Permission not needed)



The three-point relationship between the laser diode, the projection of the reflected beam onto the CCD array/CMOS, and the measuring point on the target object is used to determine the final distance to our desired measurement target. What is important to note here is how manipulating the position of the laser diode and detector impacts the maximum range we are able to detect. Alignment of the system is critical for the reliability and stability of the measurement system. Often the maximum charged pixels from the reflected beam is what is analyzed on the CMOS detector and the rest of light from diffuse reflection can be filtered out by digital signal processing. In order to achieve high resolution using laser triangulation, the critical element is the associated projection optics in keeping the beam size small as it propagates large distances. The spatial resolution of our system is dictated by the beam size as to what the smallest feature we can resolve. In addition, a larger photo sensor size also enables improvements in speed, sensitivity, and depth of view.

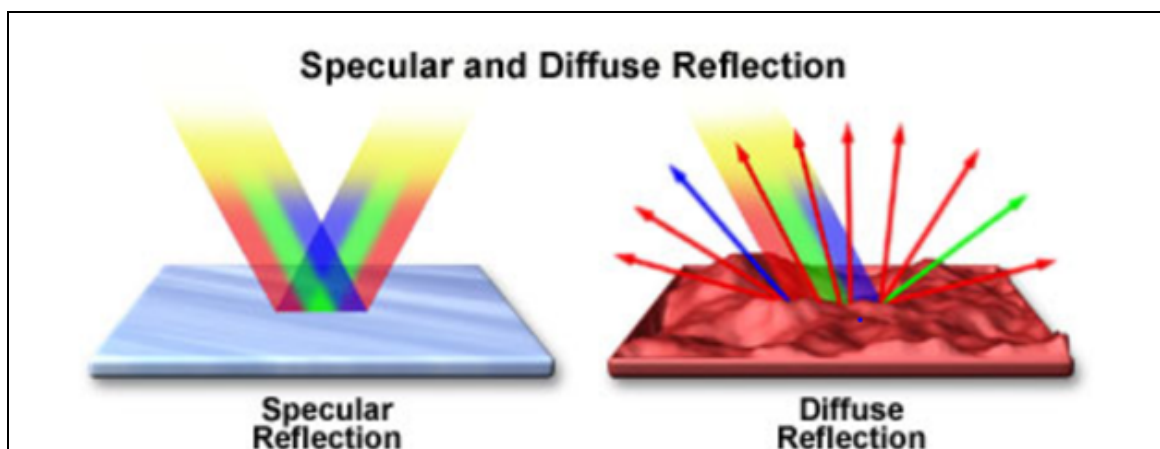
Overall, the laser triangulation method would be very effective for our requirements of non-contact measurements of objects. The challenge of using the laser triangulation method in our case would involve potentially calibrating our system for distance measurements of materials with different reflectivity on their surfaces. In addition, the shape of our object could impact readings as well due to the diffuse or specular reflections that can occur impacts the angles that light is reflected.

Diffuse reflection would impact laser triangulation by potentially scattering light in all directions. The challenge of building a diffuse reflection laser triangulation system is being able to image the laser spot size onto the surface of a CMOS. Specular reflection would impact laser triangulation by the requirement to angle both the laser transmitter and the receiver towards each other. If the laser triangulation system was perpendicular to a shiny surface, none of the reflected light would ever make it to the receiver.

Another critical component in the design of the laser triangulation system is how the light will be reflected off an object and the amount of light reflected off the object. The reason this parameter must be considered is because most objects that the laser beam will interact with in the world are not smooth mirrors where the incident light will be reflected equally. Different objects, materials, and surfaces will have different amount of reflectivity and absorbance of wavelengths. Furthermore, the two types of reflection that can occur are specular reflection and diffuse reflection. Specular reflection is light which is reflected from a smooth surface at a defined angle. Example of these types of surfaces could be metal.

Diffuse reflection is reflection off a rough surface which tends to send reflected light off in all directions when the incident light interacts with the surface. For these reasons the design of the laser triangulation system weighed more on encountering diffuse reflections as the user was more likely to experience these situations in their everyday environment.

Figure 13: Specular and Diffuse Reflection (Permission requested)

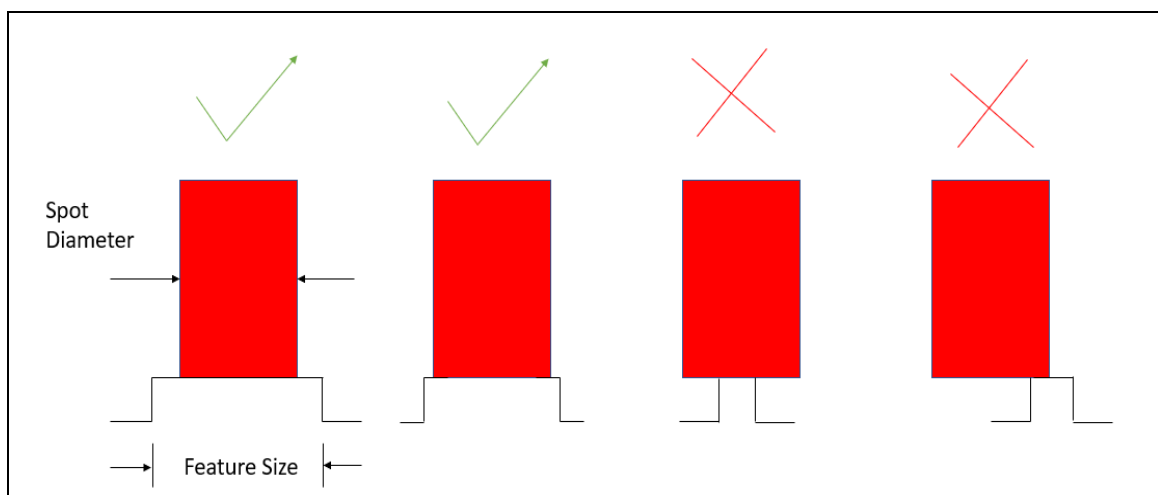


In order to make sure we do not saturate the detector, power considerations of the laser diode used will be considered. While laser triangulation is typically done using a red laser diode in industry, we would not be able to use the red laser diode due to the risk of harm it poses to the public. {Epsilon, 2017 #17} To overcome this challenge, we have opted instead to use an infrared laser and

diode with a wavelength of 905 nanometers which is deemed as “eye-safe”. The camera/CCD/CMOS will need to be able to detect the infrared and this may require removing an infrared filter if it is installed. In addition, to make sure we do not get any stray light onto our detectors and make the data processing easier we may opt to place a narrow bandpass filter with a +/- of 1 nm on our detector as well. The bandpass filter filters out all non-laser wavelengths of the incident light.

One key component in our laser triangulation system is whether the laser triangulation system uses a laser spot or a line laser. The benefit of using a laser spot is we will be able to resolve small feature sizes. The figure below demonstrates how the laser spot size impacts what you are able to resolve. Resolution is often defined as the distance at which you can distinguish two points. If the spot diameter is smaller than the feature size being measured then you will be able to resolve the feature else you won't.

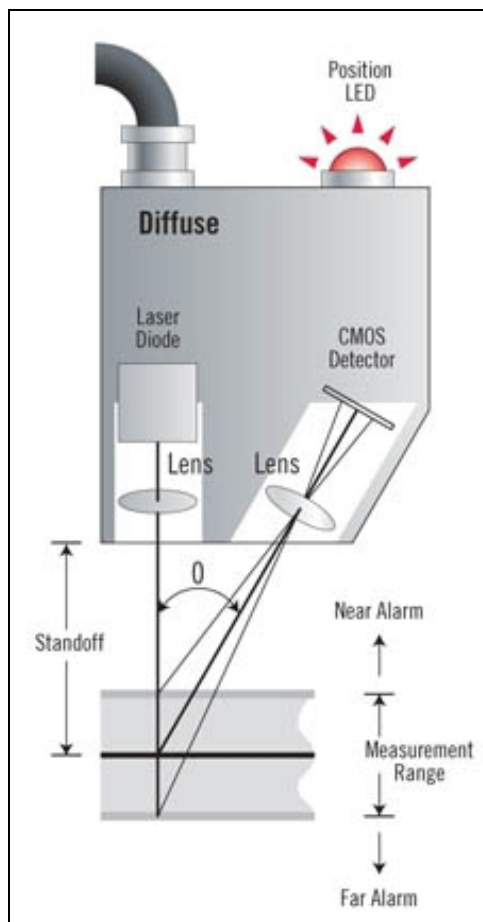
Figure 14: Spot Size (Permission not needed)



In addition, the required optics to collimate the laser beam are straightforward and simple. One downside of using a laser spot is the impact of the surface roughness of the object being detected impacting measurements due to diffuse reflections. The benefit of using a line laser is the additional collecting of points will improve the accuracy and precision of distance measurements due to averaging. The measurements are not affected by surface roughness or unevenness. {, 2018 #18} The challenging of using a line laser would be acquiring the necessary beam-shaping optics as well as the additional complexity it adds to the programming algorithm used to detect and calculate distances. For the specifications and requirements of the project, a laser spot was selected over the line laser.

A laser line triangulation was also not chosen over a single point laser triangulation because laser line triangulation provides too much information. Laser line triangulation is typically used in 3D scanners and without the need of 3D profile information has ruled it out. The conventional packing of a manufactured laser triangulation system can be seen below in the figure below. What is important to note is the working ranges of detection. What is meant by working range in the laser triangulation system is essentially the shortest range the laser triangulation system can detect and the maximum range. {Breier, 2015 #19} As light reflects off the object, sometimes the beam displacement on the sensor can be located somewhere off the CMOS detector. If this is the case, then the object would not be able to be detected and thus no range measurement could be made.

Figure 15: Commercial Laser Triangulation Design (Permission requested)



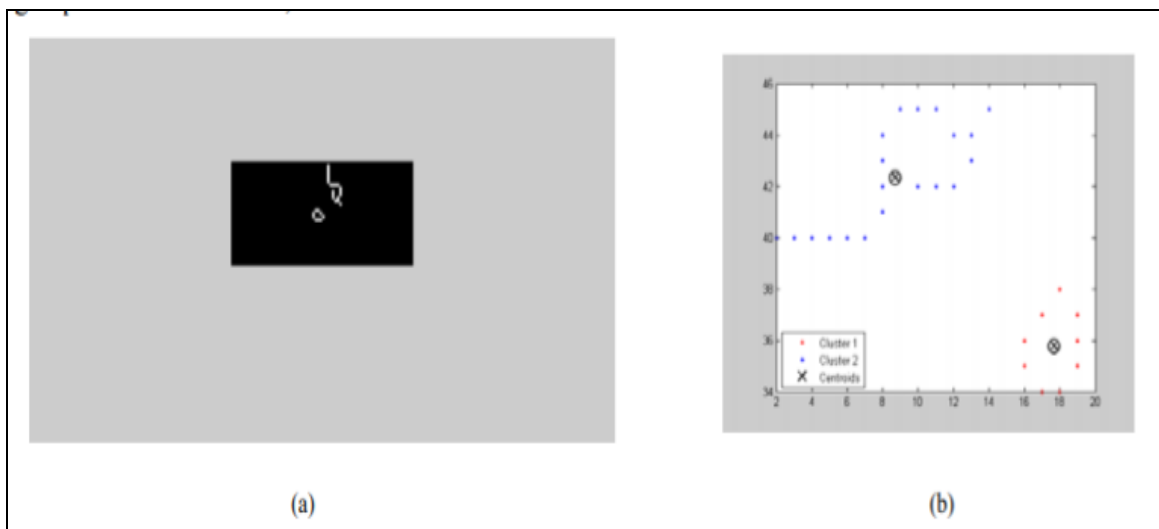
Furthermore, laser triangulation can also be done using a computer vision approach. How the computer vision approach works is a computational approach in determining the distance of the target object to the sensor were

explored. The computational approach involves Matlab which is a commercial software used in Academia and industry to analyze and process images.

In the Matlab approach an image is taken from the CMOS camera and transferred to a PC. The bandpass filter placed in front of the CMOS to ensure that the details that are captured are solely the wavelengths being emitted from the laser. The image would consist of the background scene as well as the laser beam spot. From this step, the image is converted from an RGB image to a grayscale image. This procedure helps detail each pixel in the image as an intensity value from 0 which corresponds to white all the way to 255 which corresponds to black. The images becomes “simplified”. In his paper on the topic, Shojaiepour writes that Canny filter is applied to locate the edges of the laser beam and isolate the details further. {Shojaiepour, 2010 #20}

A sample image of the laser beam spot isolated after all the Matlab image processing tools can be seen in the figure below. The shape is then measured from a reference point defined by the user.

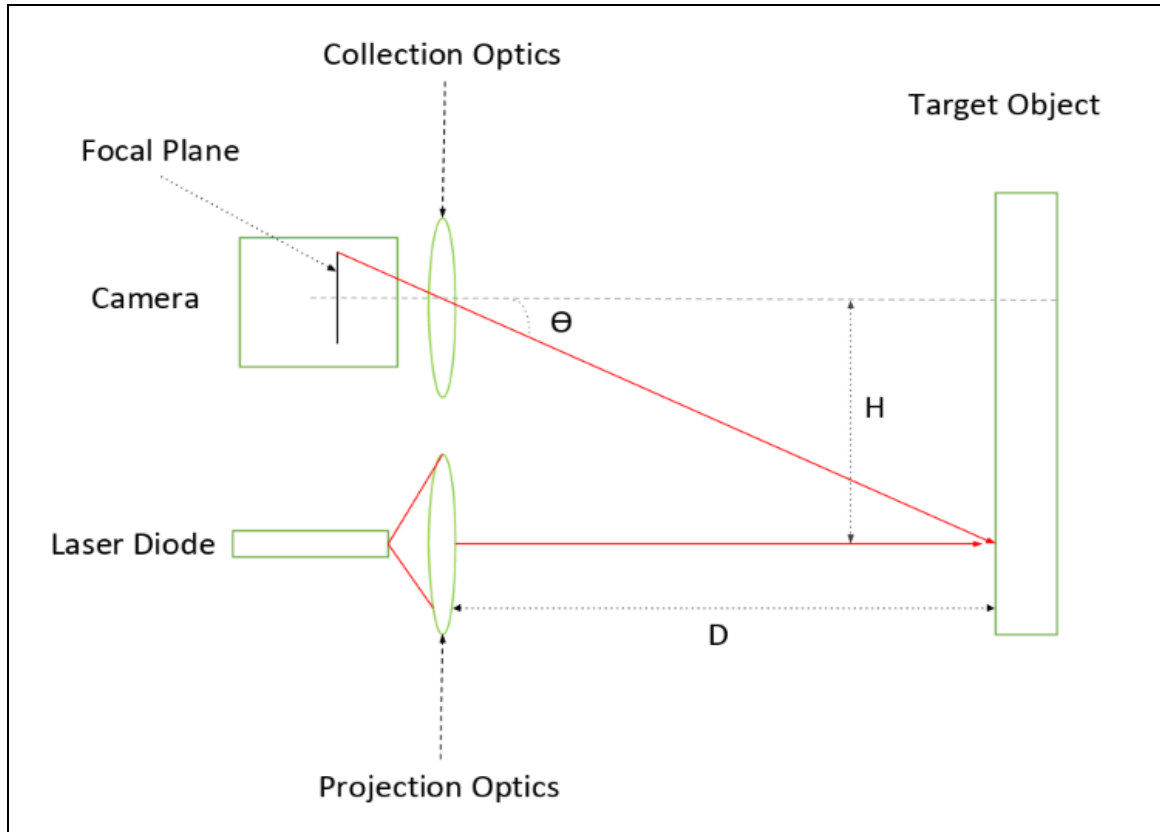
**Figure 16: Computer Vision Laser Triangulation Technique
(Permission Requested)**



Shojaiepour further goes on to explain that the laser beam must be calibrated to a point parallel to the camera’s viewing direction. {Shojaiepour, 2010 #20} If the laser beam is not calibrated to a point parallel to the camera’s viewing point then the laser will not be able to hit objects near the center of the camera’s field of view. This can in turn impact the calibration of the system and thus the reliability. With the known distance between the laser pointer and the CMOS camera, the distance is computed using a custom MATLAB algorithm computing the location of the pixel hit by the diffuse reflection from the object. The Matlab program algorithm typically calculates the number of pixels the laser spot is displaced

from the center. The trigonometric relationship of triangles and angles is then used to estimate physical distance in the world as seen in figure below.

Figure 17: Laser Triangulation Design (Permission not needed)



The geometric relationships represented mathematically are:

$$\tan(\theta) = \frac{H}{D}$$

$$D = \frac{H}{\tan(\theta)}$$

$$\theta = P * R * rad$$

where,

P = number of pixels from center of the focal plane

R = Radians per pixel inch

Rad = radian compensation for alignment error (determined by user)

For these reason, these equations can give an approximation when designing for the maximum range of detection of objects within the laser triangulation system.

The laser triangulation system with computer vision works with comparable results to conventional laser triangulation with CMOS detectors. The difference is with computer vision the programming required is extensive and it is a brute force method requiring a lot of wasted memory. As we will outline in the coding strategy in the later section, the laser triangulation system with CMOS detectors is far more elegant and remains a strong candidate for the execution of the project.

3.2.7 Flash LIDAR

Flash lidar uses an array of laser emitters and an array of photodiodes. Collimated light passes through the diffuser lens to form a wide horizontal and narrow vertical laser beam. The light beam reaches the object and the light is reflected off of the object. Light is then captured onto the receiver lens and focused onto the photodiode array. The laser sequentially pulsing the wide horizontal and narrow vertical beam combined with the processing is what enables a 3D matrix to be made from the individual measurements. Flash LIDAR can be thought of as illuminating all these points in an instant. Flash LIDAR has also been done using depth sensing arrays. While this technology holds the capabilities to capture a lot of information, it is deemed excess for the scope of our project. The flash LIDAR would be collecting intensity, color, image, and depth. The focus of our project is more on the realm of a single point LIDAR. The flash LIDAR would provide too much information and require extensive processing. This would in turn drive the size of our product making it unable to meet our requirement specifications of being portable. In addition, not many commercial products currently exist with the flash LIDAR technology which is why we have chosen to not select this method for our project.

Figure 18: Flash LIDAR (Permission requested)

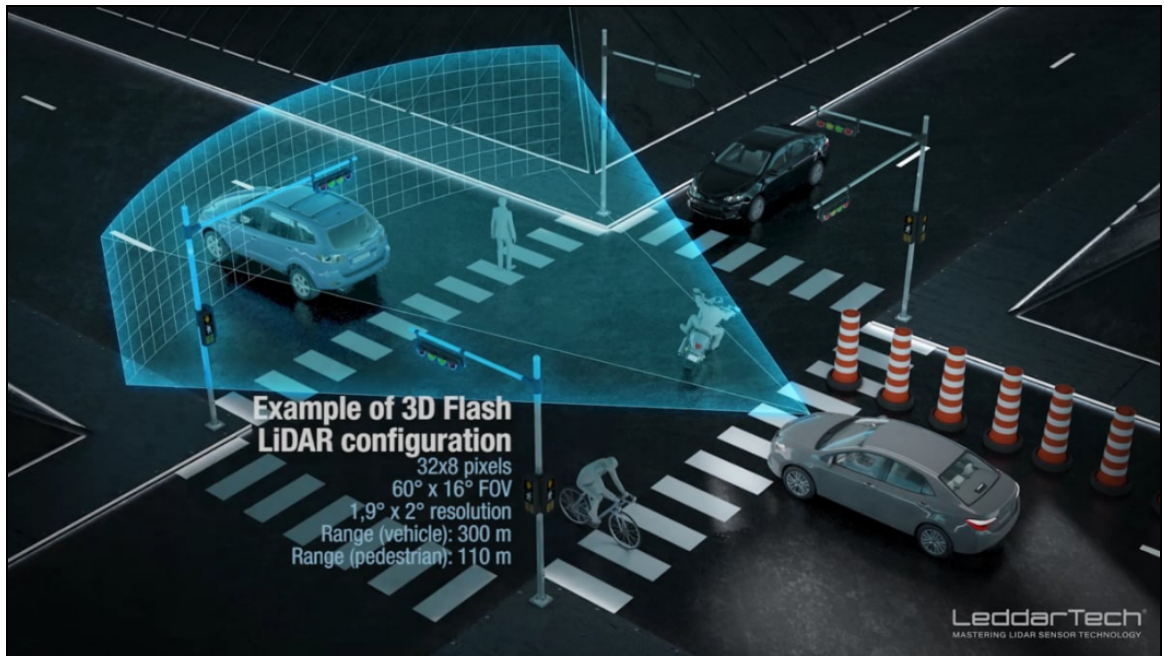


Table 9: Pros and Cons of LIDAR

Pros	Cons
High measurement rate	Negatively impacted by poor weather conditions such as rain, snow, fog
Identify distances of few centimeters out to 250+ meters	Can be expensive
Resolution	Consider absorption, reflectivity, scattering, color
Precise measurements with accuracy	Mechanical stability of Optics is critical
	Line-of-sight

Table 10: Pros and Cons of Ultrasonic

Pros	Cons
Cheap	Susceptible to noise in the environment
	Short detection range of few meters
Not impacted by weather conditions	Detection rate is slower
	Low Resolution
	Low Spatial Direction

Table 11: Pros and Cons of Laser Triangulation {Julight, 2014 #21}

Pros	Cons
Non-contact measurements	Limited working distance
Cheap	Difficult to measure on irregular and mirror-like surfaces
Easy integration and calibration	Negatively impacted by ambient light

After a comprehensive review of range finding techniques, laser triangulation was selected over ultrasonic and LIDAR. While LIDAR has great resolution and range, the implementation of LIDAR is far too difficult given the time constraints of the project. The challenge of recording the start and stop of pulses has digital signal processing the team is unfamiliar with and it was not a risk to learn all of the timing electronics needed.

Ultrasonic detection was not selected because it does not have comparable resolution capabilities to laser triangulation. Ultrasonic sensors are typically used to detect very large objects meaning it can miss objects. Soft objects also result in absorbance.

Laser triangulation remains the best candidate for the requirements of the project due to easily acquired components, reference designs, and comprehensive literature on the topic, and stability of the product. Laser Triangulation is perfect for the project because the purpose of our device is not necessarily to detect objects at a very far range, but to give a “HeadsUp” to objects a visually impaired person may be approaching.

Table 12: Summary Range Detection Techniques {Garry Berkovic, 2012 #6}

Technique	Optics	Electronics	Implementation	Range
Pulsed Time of Flight (LIDAR)	Projection, Collection Optics, Beamsplitter	Timing	Challenging	250+ meters
Ultrasonic	N/A	Timing	Easy	Up to 5 meters
Laser Triangulation	Collimation, Wide Field-of-View Lens System	Digital Signal Processing	Medium	Up to 2 meters
Flash LIDAR	Collimation, Collection	Timing	Challenging	Up to tens of meters
Interferometry	Mirrors, Beam Splitters, Collimation	X	Challenging	Micrometers to meters
Amplitude Modulation of Continuous Light	Collection, Projection Optics	Function Generator	Challenging	Millimeters to meters
Frequency Modulation of Continuous Wave	Mirror, Beamsplitter	Function Generator	Challenging	Millimeters to meters

3.3 Strategic Components and Parts Selection

The correct component selection is critical to facilitate the process of system integration among the Optics and electronics. Failure to select the right components from the beginning can lead to going over budget as well as degraded system performance. While the goal of the project is to develop an affordable visual aid to help the blind navigate the environment, datasheets were scrutinized to pick the best products. In this section, various components are compared side to side with the consideration of the final design and packaging

of the product. A comprehensive part selection list can be found at the end of this section of all the parts necessary to build the device.

3.3.1 Transmitters

The chosen technique to our laser rangefinding has been determined to be Laser Triangulation. For this reason, it is critical to select the correct light source whether it be LEDs or laser diodes. LEDs and laser diodes have different performance characteristics and this section will differentiate the two. The process of choosing LEDs vs laser diodes has impact on our design from the optical lenses, electronic circuit design, power consumption, type or receiver we use, and even packaging and housing design. This section will provide justification on our selection.

3.3.1.1 LEDs

LED stands for light emitting diode. The spectrum of a typical LED is very broadband exhibiting many wavelengths. LEDs would not be able to be implemented in a laser triangulation sensor due to the high divergence of light being emitted. An achromat would surely need to be used to correct for the chromatic aberrations in the system. For these reasons, LEDs were ruled out as a light source.

3.3.1.2 Lasers

Laser stands for light amplification by stimulated emission radiation. A laser makes the ideal light sources for laser triangulation sensors because the beam can be collimated to maintain about the same spot size for the desired measuring range. The spectrum and linewidth of a laser is also very narrow. By combining the narrow linewidth of a laser and a narrow bandpass filter, it becomes easy to develop a laser triangulation system which is not impacted by ambient sunlight.

The laser selected for optical device was has a wavelength of 905 nm. This wavelength was selected because of eye safety. Typical wavelengths of laser beams used in self-driving car industries for LIDAR systems include 905 nm, 1310 nm, and 1550 nm. However, due to the high cost and long lead times in sensors in the marketplace, the 1310 nm and 1550 nm laser diodes were not used. These wavelengths would improve the project due to the reduction in eye sensitivity to the 1310 nm and 1550 nm could ultimately allow us to adjust the power output accordingly. This in turn helps the digital signal processing due to the ease in detection. For this reason the 905 nm laser diode was chosen due to the cheaper components available in the market. The two 905 nm laser diodes evaluated for this project included the ThorLabs L904P010 and OSRAM Opto

Semiconductors SPL_PL_90_3. The ThorLabs laser diode was selected over the OSRAM because the OSRAM would not meet the requirements to be “eye-safe”. Additional neutral density filters would need to be added and in that process it would add unnecessary size to the prototype. The characteristics for the respective laser diodes can be seen in the table below:

Table 13: Comparison of NIR Laser Diodes

Laser Diode	ThorLabs L904P010	OSRAM Opto Semiconductors SPL_PL_90_3
Cost	\$26	\$23
Beam Divergences ($\theta_{ }$, θ_{\perp})	8, 25	9, 25
$\Delta\lambda$	20 nm	7 nm
Output Power	10 mW	75 W (Peak Pulse)
Operating Current	50 mA	750 mA
Operating Voltage	2 V	9 V

Table 14: Pros and Cons of Light Emitting Diodes

Pros	Cons
Cheap	Collimating optics difficult
Eye-safe generally	Broad Spectral Width
Easy Circuitry	Receiver implementation impossible in outside environment

Table 15: Pros and Cons of Laser Diodes

Pros	Cons
Monochromatic	Eye-safe requirements

Collimated	Complex circuitry due to temperature stability
Fast Switching Speed	Expensive
Easy pairing with receiver/system integration	

3.3.2 Receivers

The receivers for the laser triangulation are instrumental in being paired with the laser transmitter. The requirements for the charge coupled device, complementary metal oxide semiconductor (CMOS), position sensitive photodiode are to have a fast response time, infrared regime sensitivity, and high signal to noise ratio. This will allow us to be able to use the device efficiently to convert light energy into useful electrical energy for processing.

3.3.2.1 SNR

Signal-to-Noise Ratio (SNR) is a self-explanatory parameter of a system detailing the ratio of intended signal to unintentional noise in a system. It is the base parameter for most communication and detection systems, that highly influences the performance of a system such as bit error rate (BER) in communications as well as probability of detection and false alarm rates.

A common way of describing SNR, despite being unitless, is the decibel (dB). Decibels convert unitless ratios into a logarithmic value that can be more manageable than vast linear scales. The basic conversion of ratios into decibel units is as follows:

$$X_{dB} [dB] = 10 \times \log_{10}\left(\frac{X_1}{X_2}\right)$$

This is the basic definition of a decibel as far as mathematics are concerned. This definition holds for ratios of power, such as that which is used to describe the losses in a fiber by comparing the power at the output of a fiber to the power that has been coupled into the fiber. However, in most electronic applications we compare voltages or currents rather than power. Because voltage and current both scale quadratically to power, the square of the ratio must be compared, as follows:

$$V_{dB} [dB] = 10 \times \log_{10}\left(\frac{V_1^2}{V_2^2}\right) = 20 \times \log_{10}\left(\frac{V_1}{V_2}\right)$$

By the properties of logarithms, the exponent can be replaced by a scalar multiplication in front of the term. As such, when comparing the voltage and current of a system, the SNR ratio in decibels follows this formula rather than the basic logarithmic conversion.

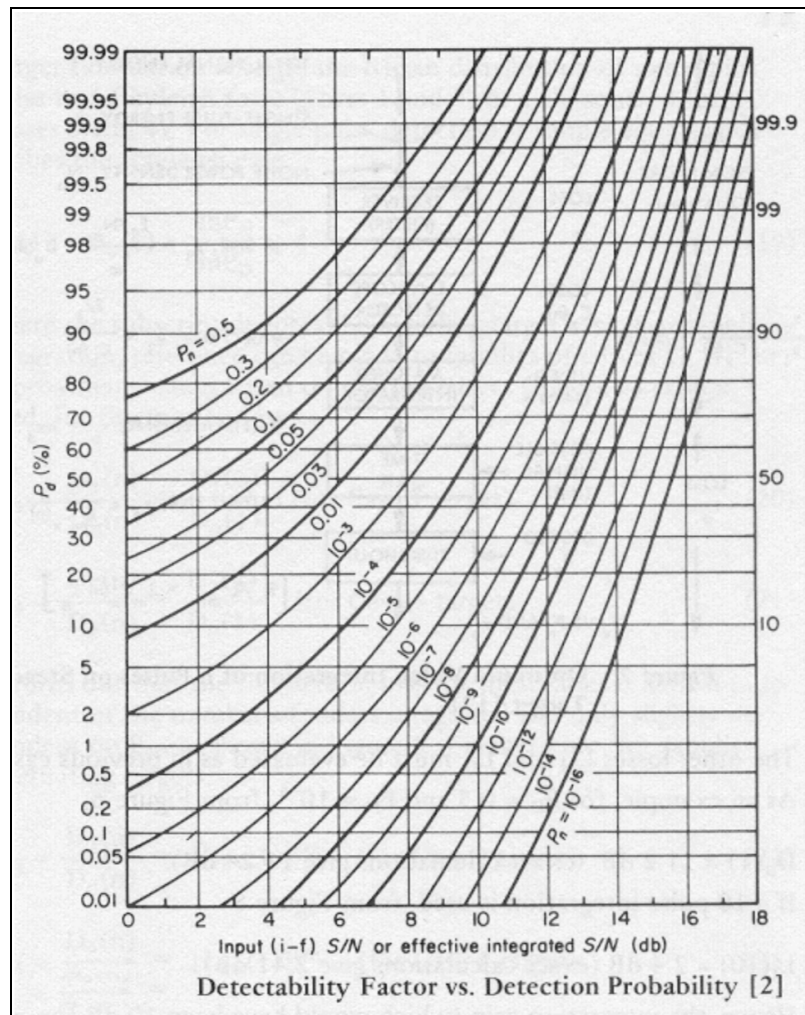
All noise inherent to receiver, such as photodiodes, are related to the Johnson noise of the device, defined by:

$$Noise = k_B T \beta \times N_F$$

Where k_B is Boltzmann's constant, T is the temperature of the device generally in Kelvin, and β is the bandwidth of the noise in the device, and N_F is a scaling factor known as the Noise Figure determined by several outside variables.

Unfortunately due to these outside factors, the scaling factor N_F is a somewhat nebulous term that is outside the scope of this paper in explaining, although it is highly dependent upon the chosen threshold values. Additionally, the mathematics involved in utilizing the base level of noise and threshold voltage or current to determine the probability of detection and the false alarm rate is lengthy and detailed, requiring a brute-force numerical analysis, and as such shall not be discussed herein. However, the end result of such calculations provides a relation between SNR, detection probability, and false alarm rate, as detailed in the following figure:

Figure 19: Signal-to-Noise Ratio (Permission requested)



Where the x-axis is the SNR of the system in dB, the y-axis is the probability of signal detection as a percentage, and the multiple plotted lines represent the false alarm rate of the system. The chart can be read by selecting the desired detection probability and false alarm rate and following that to extrapolate the

Using the above table, we are able to determine the ideal SNR for our application. For example, if we desired our system to detect our signal 90% of the time, with a false alarm rate of 10^{-6} , we require a SNR of at least 13.2 dB. For our design, this is an acceptable false alarm rate and detection probability as well as an achievable SNR, as will be covered when we discuss device sensitivities and spectrums. The data presented above is theoretical, representing the false alarm rate and detection probability for a sinusoidal pulse with Gaussian noise and without detection losses, but we can assume that our application, while not identical, will provide similar results within reason.

3.3.2.2 Sensitivity and Spectrum

There are several critical factors affecting our choice of emitter and receiver, but the most critical factors are responsivity and cost. As should be clear, we require a detector that will respond to the wavelength of the laser we are using to send a signal. We measure the degree of sensitivity at a basic level as responsivity, which is defined as:

$$R \left[\frac{A}{W} \right] = \frac{I_{out}}{P_{in}}$$

Where R is the responsivity in units of amps per watt, I_{out} is the current generated by our photodetector, and P_{in} is the incident power of light on our device. Responsivity is both wavelength and material dependent. Materials can detect light ranging from the ultraviolet to the far infrared. For us, it becomes a challenge in determining not only which material coupled with which wavelength will give us the best results, but also a challenge of analyzing the cost of such a system.

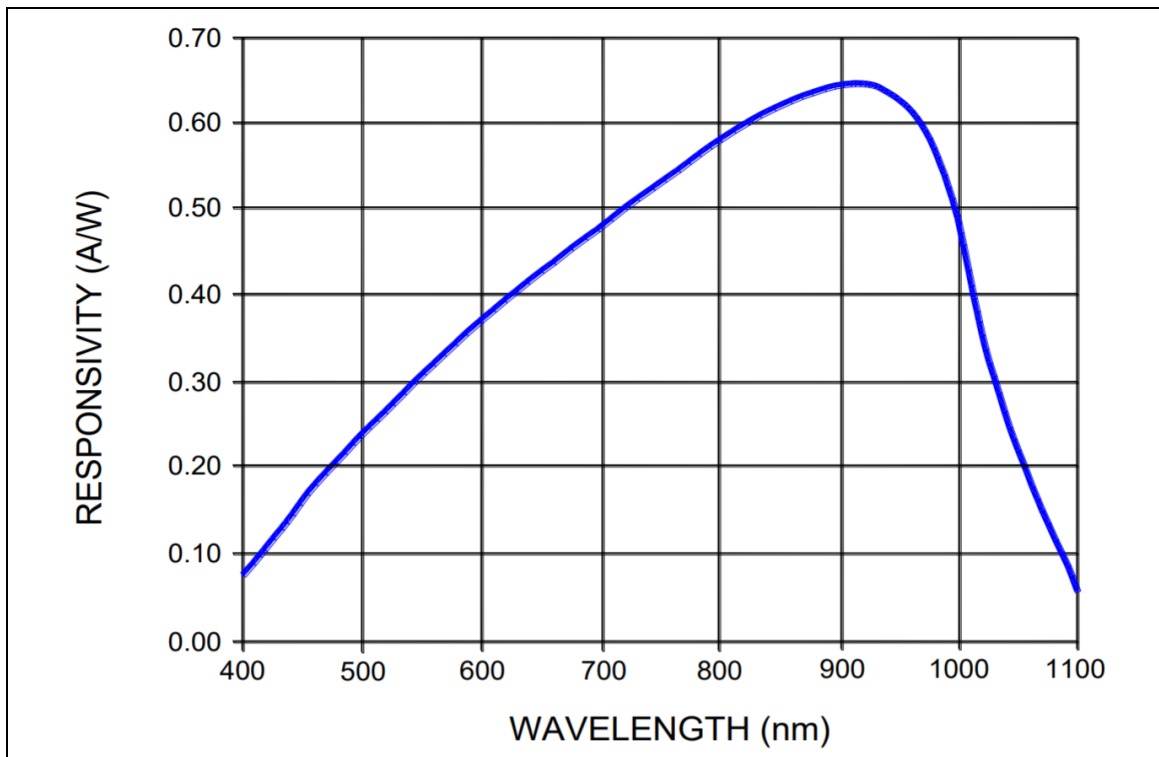
As was discussed above, our best candidates for lasers to use in this rangefinding system are at wavelengths of 905 nm, 1310 nm, and 1550 nm. Both 1310 nm and 1550 nm are standard wavelengths for communication, primarily due to their low scattering losses in air and glass. Because of their spectral dissimilarity from visible light, they are not focused by the eye to pose as severe a threat to the retina as visible wavelengths due, nor are they highly absorbed by the eye tissue. 1550 nm light is even more preferable with regards to eye safety as it has a much higher MPE than 1310 nm light, as discussed in our standards section. The most prohibitive aspect of using such sources is cost, as both emitters, namely lasers, and photodetectors are commonly made of indium gallium arsenide phosphide (InGaAsP) or indium gallium arsenide (InGaAs), as seen in the figure below. {Kasap, 2013 #22} Detectors made of this material, specifically CMOS arrays, can cost up to thousands of dollars.

**Figure 20: Material, Bandgap Energy, Cutoff Wavelength Table
(Permission requested) {Kasap, 2013 #22}**

TABLE 5.1 Bandgap energy E_g at 300 K, cutoff wavelength λ_g, and type of bandgap (D = Direct and I = Indirect) for some photodetector materials			
Semiconductor	E_g (eV)	λ_g (μm)	Type
InP	1.35	0.91	D
GaAs _{0.88} Sb _{0.12}	1.15	1.08	D
Si	1.12	1.11	I
In _{0.7} Ga _{0.3} As _{0.64} P _{0.36}	0.89	1.4	D
In _{0.53} Ga _{0.47} As	0.75	1.65	D
Ge	0.66	1.87	I
InAs	0.35	3.5	D
InSb	0.18	7	D

This detection cost is the single most important factor in us eliminating 1310 nm and 1550 nm laser sources from our design. Instead, we can focus on utilizing a 905 nm source which, while also being made from lower cost InP, is also detected very effectively using silicon detectors, as shown in the responsivity chart below.

Figure 21: Wavelength vs Responsivity (Permission requested)



As can be seen from this responsivity curve, a photodiode made of silicon will exhibit a responsivity of approximately 0.65 A/W, roughly the peak of sensitivity for silicon detectors. This makes 905 nm emissions and silicon detectors a uniquely effective and affordable solution for sensing and ranging. Despite a relatively low MPE, we can calculate an effective power

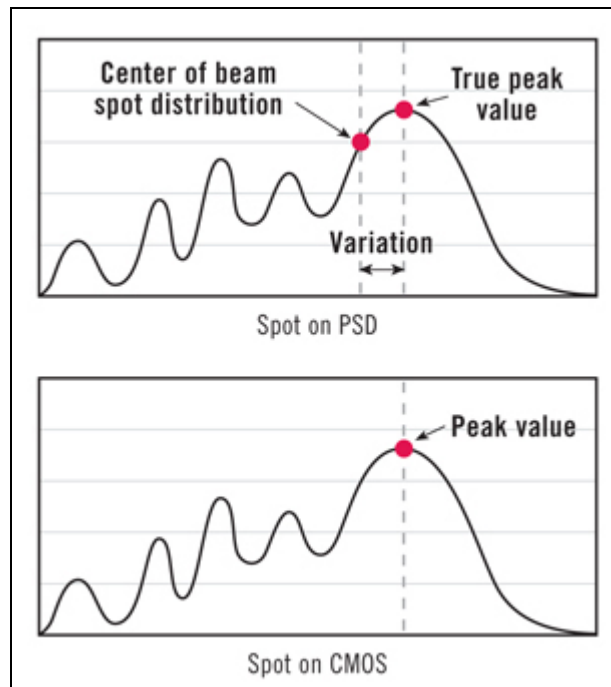
3.3.2.3 Detectors: CMOS vs. CCD vs. PSD

A very useful form of photodetectors are image arrays. These come in many forms, but most commonly come in the form of CMOS and CCD image detectors as well as PSD devices. CMOS and CCD arrays are both composed of multiple pixels, while PSDs operate based on local resistances and current flow across one large semiconductor surface.

There are two prominent methods to detect light returning from a laser emitter. The first is based on light centroid measurement. For this method, a light array sensor reads the light levels that are projected onto the face of the sensor and calculates the centroid of the beam. Sensors that use this method are called Position Sensing Detectors (PSD). Unfortunately, PSDs are susceptible to false readings by scattered laser light from surface imperfections which result in finding the incorrect centroid.

A second, and arguably more reliable, method is based on illumination strength. Similarly to the PSDs, a 2D-array of pixels reads the incoming light. However, in this method it is not the centroid that is calculated, it is the brightest pixel location. Even if there is ambient light on the sensor, no scattered laser light is going to be brighter than the true source reflection.

Figure 22: Detector Responsivity (Permission requested) {mtiinstruments, 2018 #23}



Two devices that implement this last method are Charge Coupled Devices (CCD) and Complementary Metal-Oxide Semiconductor (CMOS) Devices. Both are very similar but read in data differently. The CCD pixel array stores one frame and is read pixel-by-pixel, column-by-column. Each pixel is then amplified and read by the processor. One of the issues with this design is how slowly the pixels are read. This technology is also old and is being phased out by CMOS technology.

Instead of reading pixel-by-pixel and column-by-column, CMOS chips integrate the amplifier and sensor into each pixel which allows the processor read in the all at once. This obviously is good for speed. However it could also introduce noise into the image if each pixel sensor is not made identical to the rest. Many camera manufacturers are using both, however for most low-power and low-cost solutions, CMOS is often chosen. {Moynihan, 2011 #24}

3.3.3 Optical Lens Selection

The following section outlines the development of the imaging systems used in laser triangulation. The first section details the collimation system implemented to collimate the beam to a spot size of 1mm. The second section details the design process into developing a wide field of view imaging system to image the laser spot onto the CMOS or position sensitive photodiode. The evaluations of

the optical systems were conducted using Zemax software. Zemax software is an optical lens design software which can be used to optimize lens systems to reduce aberrations. The Zemax software also enabled us to compare different collimation designs and how it impacts beam spot size. The optimization of the lens selection is critical to enable us to keep the prototype size compact and efficient for the user.

3.3.3.1 Spot Size

Our solution relies heavily on the ability to emit and gather light from our laser diodes. Lasers are commonly believed to be collimated, traveling for a seemingly infinite distance while maintaining a constant spot size. In reality all lasers are somewhat divergent, with the cross section of least area of the beam, or beam waist, located anywhere along the optical path of the laser light. However, most types of lasers, such as gas or solid state lasers, often exhibit divergence angles on the order of milliradians or lower when properly designed and constructed, allowing for them to travel meters without any noticeable change in the beam diameter. This fuels misconception regarding laser divergence, but more importantly allows for the use of the laser without complicated collimating optics.

The spot size of the beam is critical to many applications, including ablation, imaging, and communication, amongst others. For most applications, LiDAR specifically, it is ideal for the spot size to be minimized within reason. One of the most important constraints of this project is the power output of our laser. In order to guarantee the design is eye safe for everyday use, the output power of our laser must be low enough as to not damage the eyes of others, as discussed before. The industry standard, popularized by Velodyne Systems, is approximately 2 mW per laser emission. The larger the spot size of the beam is, the lower the irradiance, making the detection of the spot more difficult. In other words, spreading the power of our laser emission over a large area diminishes our ability to collect the signal we transmit at our detector, based upon the limits of our detection system.

Additionally, spot size is specifically important to LiDAR applications as it affects the resolution and specificity of the system. Large spot sizes, by nature, will reflect off a spatially larger area than small spot sizes. As a realistic scenario, a 100 x 100 sized matrix of distances taken using ten thousand 0.1 mm beam diameter pulses can be used to generally reconstruct the features of an object with dimensions 1 m x 1 m x 1 m. However, using a single 1 m beam diameter to interact with the object will give a single distance measurement for the entire object while also eliminating the ability to gain more information because the object is of similar size to the beam diameter. There is also an issue with clipping: a particle in the air, such as dust or an insect, may reflect light from a 1 m beam back to the sensor before much of the rest is, causing errors in the

detection. While the concern of measuring several thousand times to scan an object is not directly a concern of this project, the ability to direct and particularize the angular direction of object detection is and, as such, a small spot size is important for functionality.

It is also important for our beam diameter to appropriately match the packaging constraints within our system. The emitter and receiver will be housed in 2.54 cm diameter tubing for form and function, meaning that, at a maximum, our beam width can reach 2.54 cm before being wastefully scattered or absorbed by the housing. Additionally, the two detectors we have identified as potential components for the project have active detection areas of 1 mm and 0.15 mm in diameter, respectively. As such, for both efficiency and detection purposes, the beam size upon gathering at the detectors will ideally match or be smaller than this size in order to maximize the power of our signal at the detector. Achieving a small spot size with a laser diode is a relatively simple matter of geometric optics, but forming a perfectly circular beam is difficult due to the divergent nature laser diode beams, as will be covered hereafter. However, a perfectly circular beam is unnecessary for the scope of this project.

3.3.3.2 Divergence

Laser diodes, as detailed above, are unique in the world of lasers both for their cheap cost and accessibility, but also for their size, which induces other, primarily unwanted effects in the emission. As discussed above, the thin active region of a laser diode will cause light generated to diffract outwards at the output facet of the device. This means the emission beam is very much not collimated into a simple Gaussian output like other lasers, instead spreading into a fanned plane of light. While the issue of collecting diverging light has been a long solved issue thanks to spherical lenses, the light emitted from a laser diode poses a different challenge, as the emitted light will exhibit two independent divergence angles from the output.

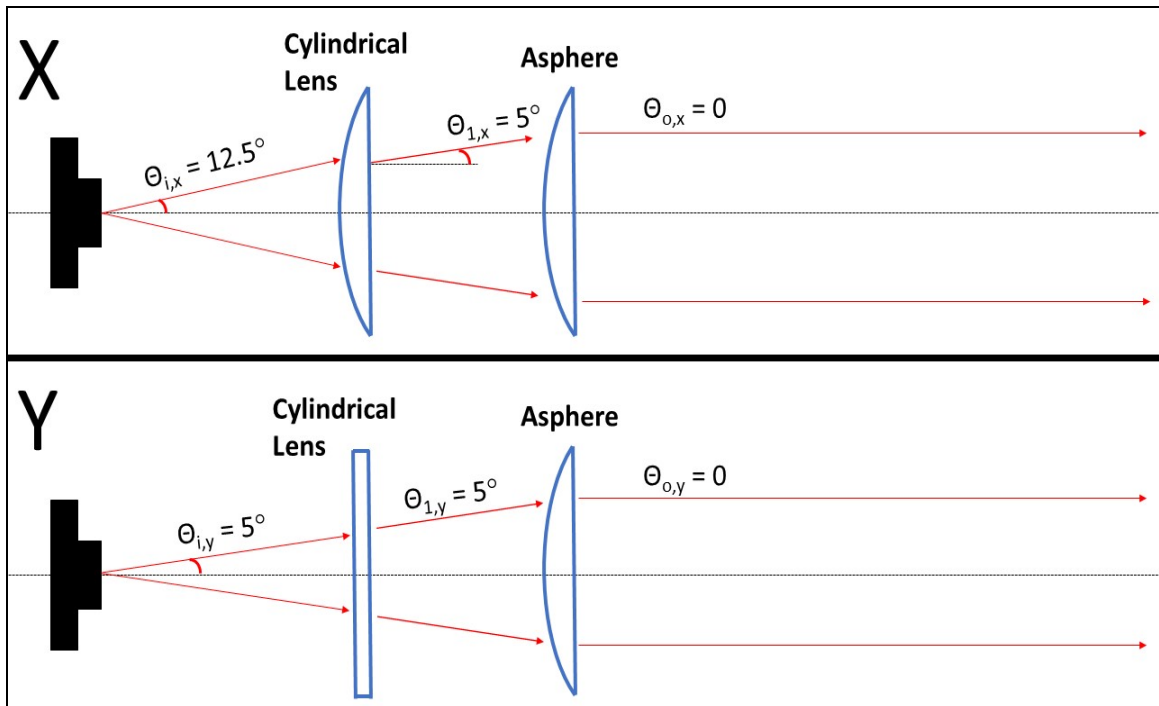
Spherical lenses are ideal for collecting and focusing light from light sources that can be effectively approximated as a point source. These sources emit light radially, with an approximately even power distribution at every distance from the source. More importantly, the divergence angle of the waves is uniform, allowing for spherical lenses, which are uniform in all axes, to properly focus and collimate light from such sources. However, spherical lenses are inadequately suited to collimate laser diodes, due to the axis-dependent divergence angle. If a positively-powered spherical lens was used to appropriately collimate one axes, the other would either remain divergent, or focus to a point beyond the lens and diverge once more. As such, we must utilize what is known as an aspheric lens.

The term aspheric is self-explanatory: it is a lens that is not manufactured to match the curvature of a sphere. Because the curvature of the lens is not

uniform in all spatial dimensions, several axes of differing optical power can be identified. For example, a cylindrical lens would exhibit a uniform curvature in one dimension, but not in another. This would change the vergence of rays passing through the curved dimension, while leaving the vergence of rays passing through the other unaffected. Comparatively, a spherical lens exhibits a focusing effect on all axes identically, while a cylindrical lens exhibits a focusing effect only in one dimension. For use with our laser diode, which exhibits two independent divergence angles, we require a lens that exhibits two different optical powers, as to collimate the two axes simultaneously.

However, such a lens is generally not available for purchase, as the two divergence angles exhibited by the laser diode are wavelength and active area dependent. This means that not every lens can possibly be designed to collimate our chosen laser diode, and there are in fact none available on the market. As such, we have opted to use two lenses, one cylindrical and one aspheric. We can achieve successful collimation by using the cylindrical lens to change the vergence of the highly divergent dimension to match that of the lesser divergent angle, then using an asphere to collimate the now symmetrically divergent beam, as shown in the following figure.

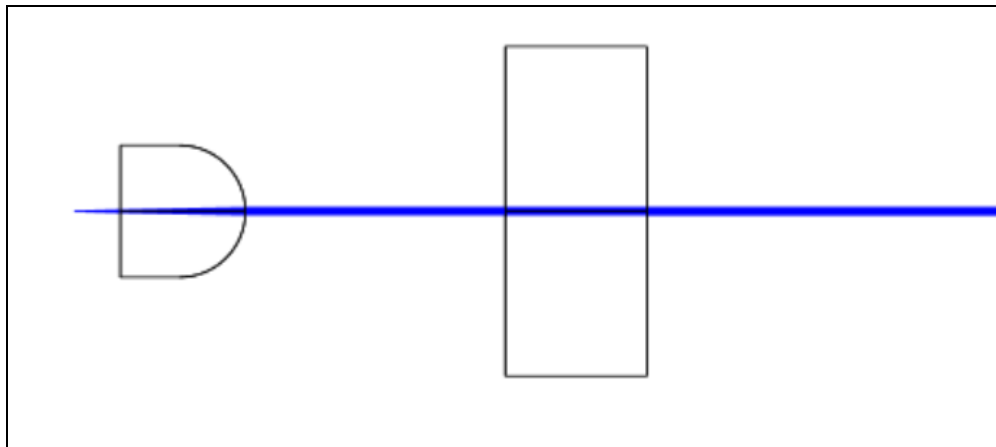
**Figure 23: Collimation of Laser Beam using Cylindrical Lens and Asphere
(No permission needed)**



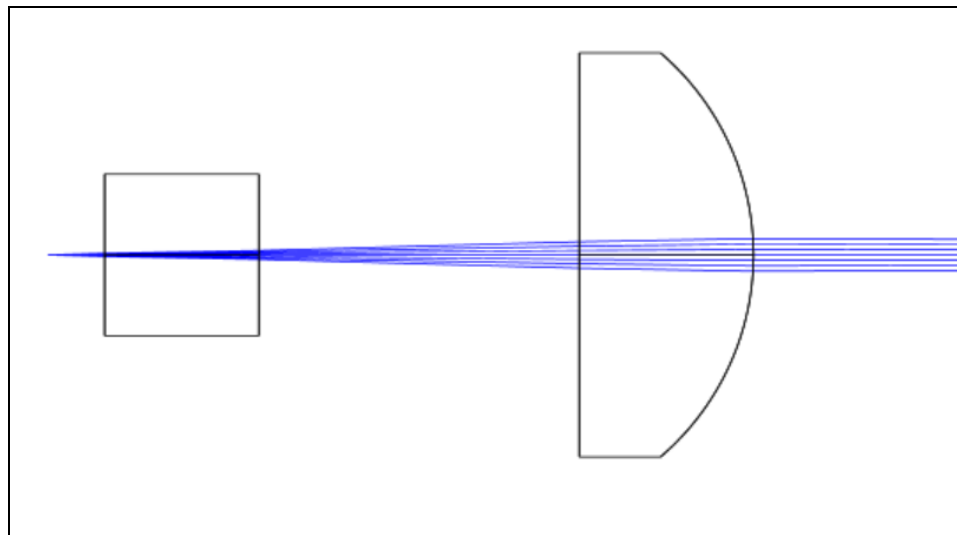
As we can see in this diagram, the beam emitted from a theoretical laser diode experiences a divergence angle of 12.5° in the x-direction and a divergence

angle of 5° in the y-direction. The use of a cylindrical lens oriented in the x-direction changes the angle of the x-divergent to match the angle of the y-divergent light, which remains unchanged because the cylindrical lens only exhibits curvature in the x-dimension. As such, because the beam divergence is now uniform, the light can be collimated by a standard asphere. Below is a group of other zemax simulation of the ray tracing that would occur for the various optical lens combinations:

**Figure 24: Collimation using Two Plano-Convex Cylindrical Lenses X View
(No Permission Needed)**



**Figure 25: Collimation using Two Plano-Convex Cylindrical Lenses Y View
(No Permission Needed)**



The cross section zemax selections seen in the above figures show that the a laser diode can be collimated using a combination of two plano-convex

cylindrical lenses. The first iteration of the lenses selected show that the beam size is not completely the same with the horizontal beam spot size being 1 mm and the vertical beam spot size being 4 mm. Further investigation can be seen done in the spot diagram below:

Figure 26: Spot Diagram in the X-Dimension (No Permission Needed)

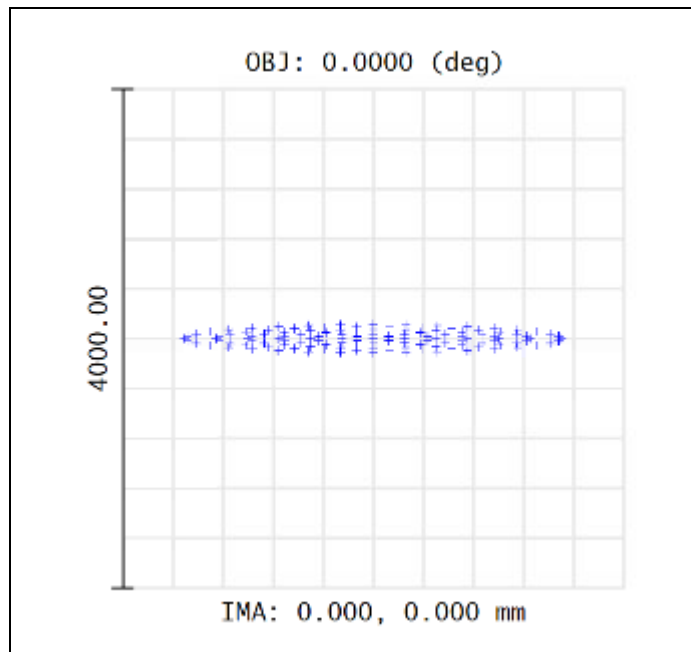


Figure 27: Spot Diagram in the Y-Dimension (No Permission Needed)

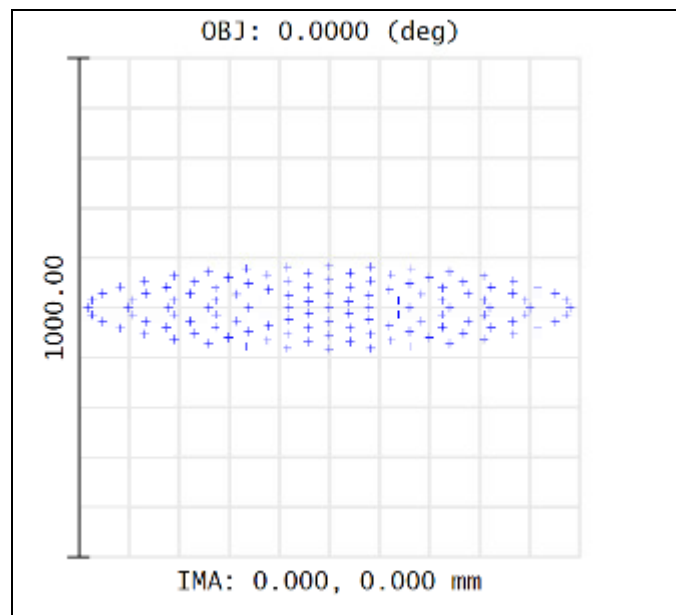


Figure 28: Physical Optics Propagation #1 (No Permission Needed)

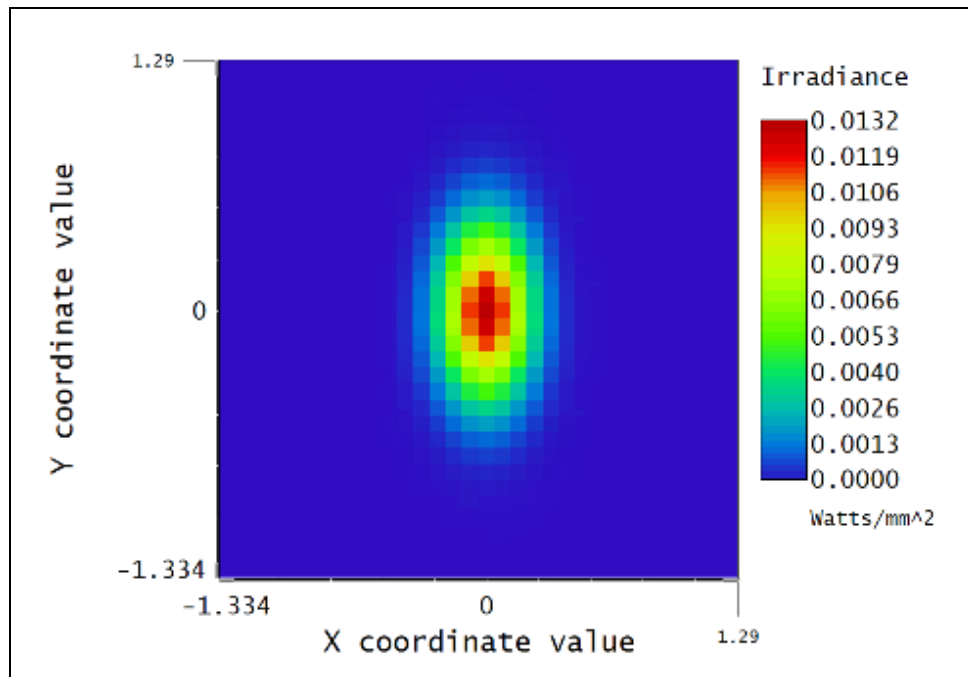
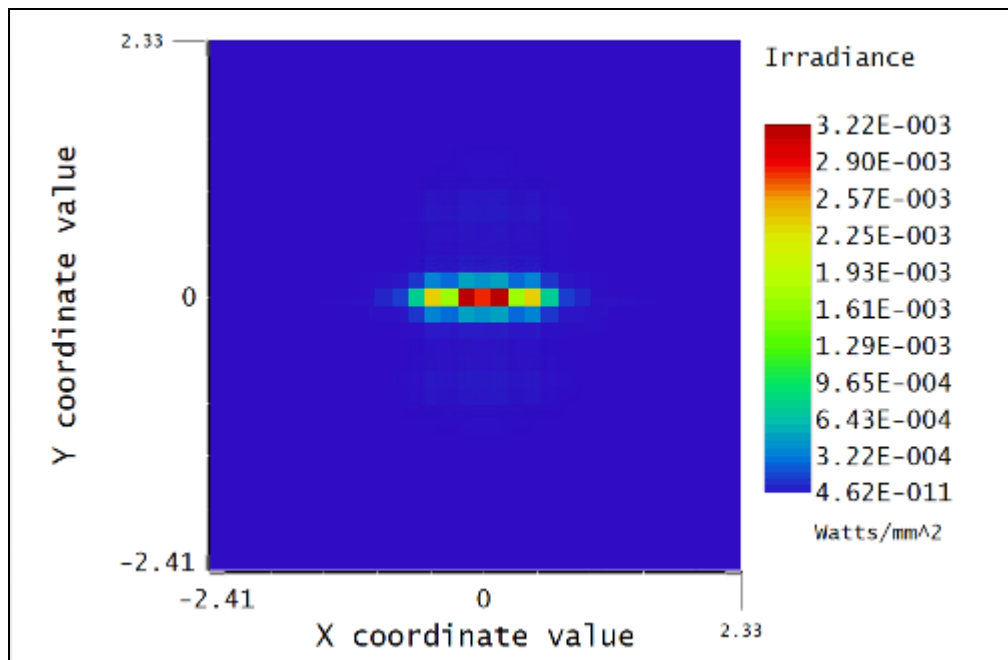


Figure 29: Physical Optics Propagation #2 (No Permission Needed)



The optimize function in Zemax was used to find better optical lenses to circularize the diverging beam from the laser diode. The collimation model simulation from the laser diode can be seen in the two figures below. This led to the lens selections of the LJ1942L1-B and LJ1402L1-B plano-convex cylindrical lenses.

Using these two lenses and the appropriate divergence angles for our chosen laser diode, we can see that the diverging beam can be collimated well in both dimensions in the following figures. Additionally the beam profile is better at infinity using these two cylindrical lenses, with a more even, less oblong, more regular power distribution.

Figure 30: Cylindrical Lens Collimation X Dimension

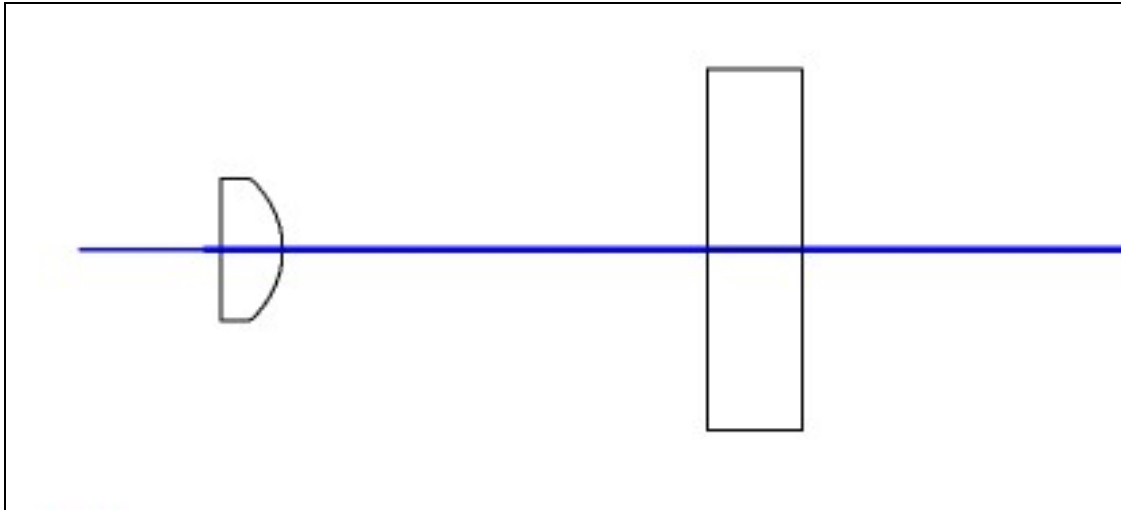


Figure 31: Cylindrical Lens Profile X Dimension

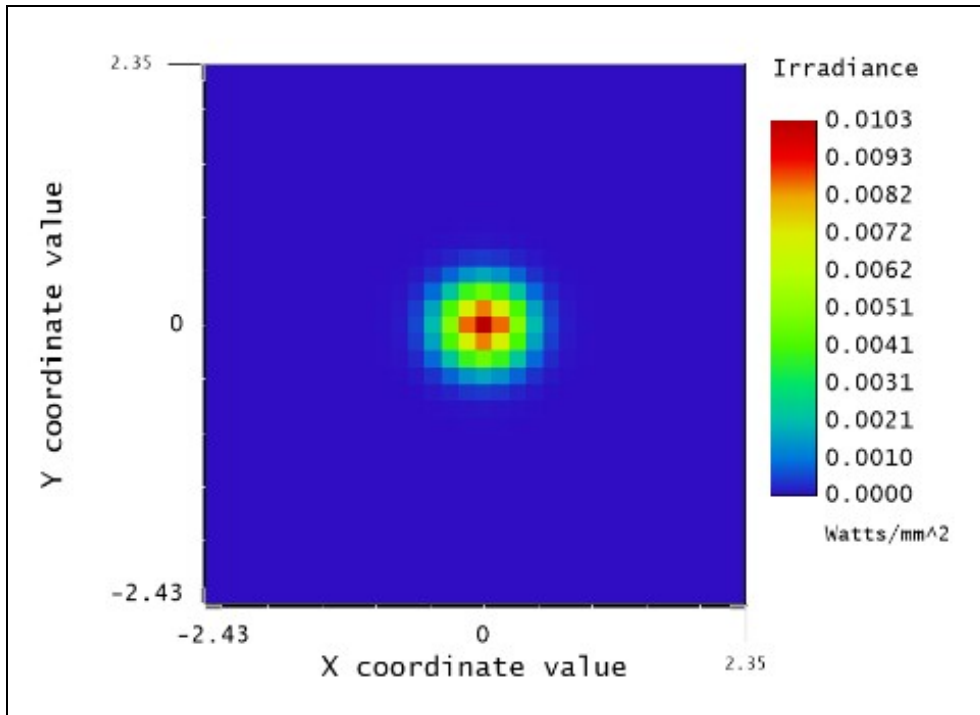


Figure 32: Cylindrical Lens Collimation X Dimension

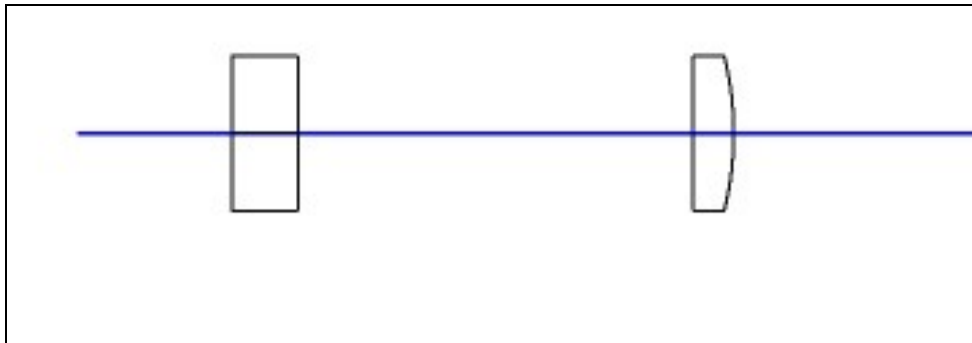
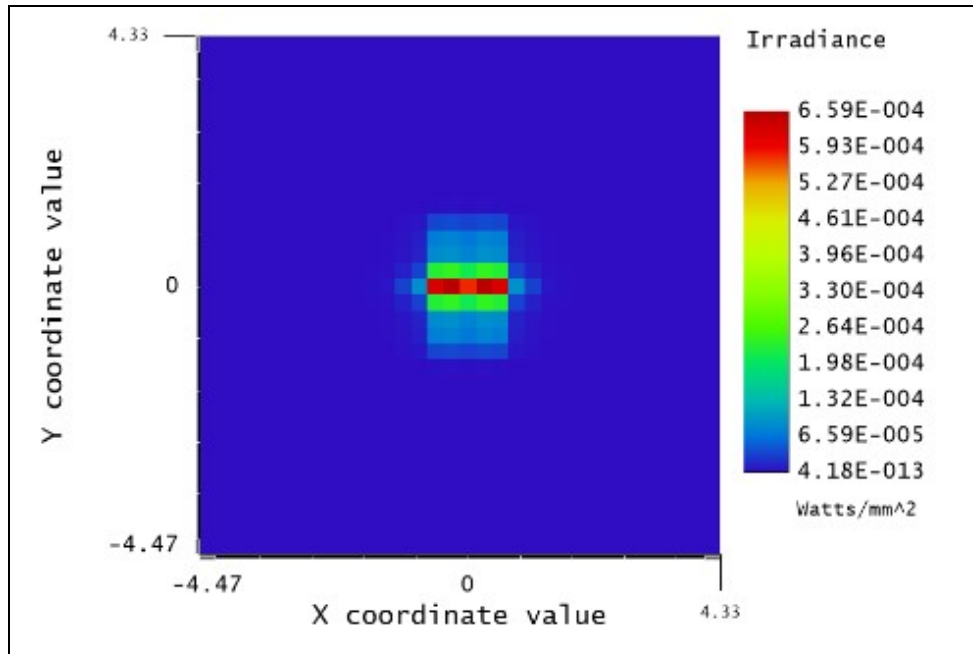


Figure 33: Cylindrical Lens Profile Y Dimension



Additionally because we are using these optics to collimate somewhat closer to the output of the laser diode, we can see that we end up with a good beam size at the end, with a width of approximately 0.6 mm and a width of approximately 0.15 mm. This will be good for energy density and imaging on to the detector. The greater spacing of these two lenses compared to lenses with shorter focal lengths will make alignment and packaging more manageable as well.

Table 16: Optical Lens Evaluation for Collimation

Collimation	Size	Cost	Beam Diameter Control	Integration into Housing
Plano-Concave Lens + Plano-Convex Lens	Small	\$100	Good	Medium Difficulty
Plano-Convex Lens + Plano-Convex Lens	Medium	\$100	Excellent	Easy
Cylindrical lens + Asphere	Medium	\$100	Fair	Medium Difficulty

Aspheric Lens	Small	\$55	Fair	Easy
Aspheric Lens + Prism Pairs	Medium	\$200 +	Excellent	Challenging Due to Angles of Prisms

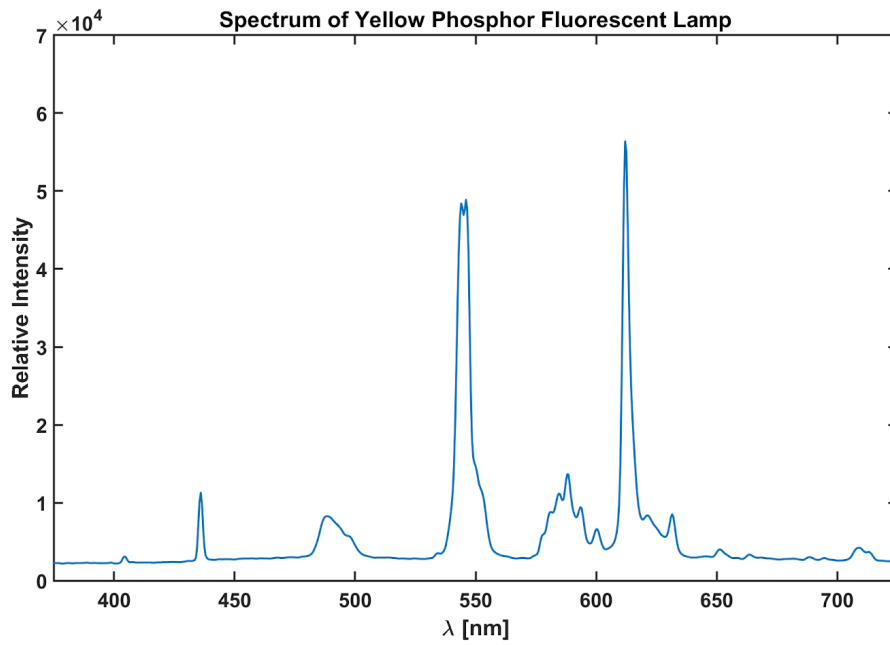
3.3.4 Bandpass Filters and Filtering

As discussed prior, a critical component affecting the success of our system is the signal-to-noise ratio (SNR) of our system. If we fail to achieve an acceptable SNR, we will be unable to consistently detect and report on the signals we use for rangefinding. In order to reduce background noise and thus increase our SNR, it would be prudent to utilize some form of filtering of incoming light onto the detector. We have two main options for filtering: diffraction gratings and bandpass filters.

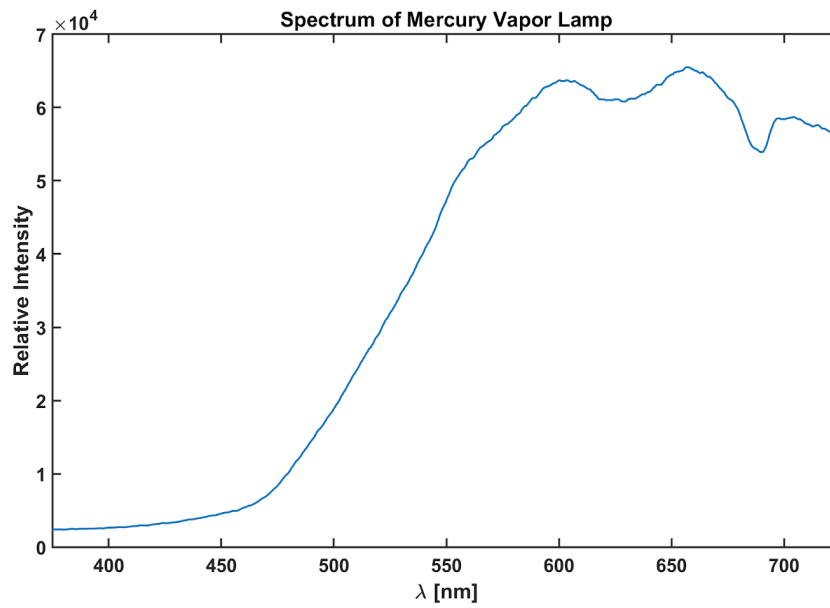
Our product is designed to utilize a laser diode with a very thin bandwidth. The wavelength we have chosen is centered around 905 nm and exhibits a bandwidth of ± 2 nm for a variety of reasons, including eye safety and cost effectiveness. As far as detection and SNR are concerned, however, this wavelength is also a good choice.

The primary source of background noise in this project will be from the ambient environment, as our device should work anywhere a user may need to traverse. This includes not only homes, offices, and stores, but the outdoors as well. Below is a diagram showing the emission spectrum of a standard yellow phosphor fluorescent lamp, as is commonly used in many lighting applications such as grocery stores and offices, as well as a mercury vapor lamp, which are commonly used in low lighting environments such as cinemas and laboratories. A standardized emission intensity is plotted against the wavelength of emitted light in nanometers. It is clear to see that neither fluorescent and vapor lamps do not emit very much in the 905 nm range. However, they do emit strongly at visible wavelengths, meaning that any filtering technique we choose should allow for the elimination of all background noise light in such an environment.

**Figure 34: Spectrum of Yellow Phosphor Fluorescent Lamp
(No permission needed)**

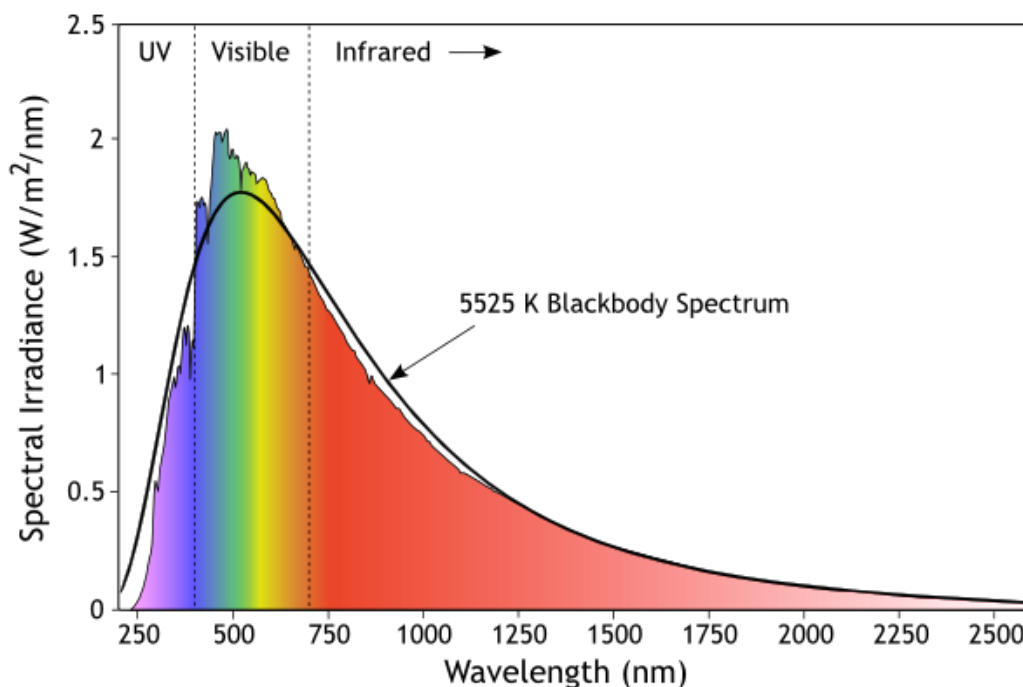


**Figure 35: Spectrum of Mercury Vapor Lamp
(No permission needed)**



A more challenging barrier for the project in terms of filtering is use of the product outdoors, during a bright, sunny day. The sun is essentially a blackbody source, as can be seen in the figure below, where irradiance is plotted against the wavelength of emitted light in nanometers. While the emission spectrum peaks in the visible range and drops off quickly in the infrared, the powers are far more comparable than what is presented by fluorescent lamps and other indoor lighting. Additionally, the sun emits at much higher powers than most indoor lamps, on top of exhibiting a smooth, gradual transition between emission wavelengths. This means it will be a not-insignificant presence of light at wavelengths surrounding our transmission signal.

Figure 36: Solar Spectrum (Permission requested) {Kasap, 2013 #22}



To filter out the extraneous signals in the environment, we have essentially two options: diffraction gratings and bandpass filters. When comparing component prices, the diffraction grating costs about two-thirds of what a bandpass filter matching our wavelength costs.

Our proposed use of a diffraction grating would be to correctly position the device to direct our intended signal into the detector while sending all background signals away from the detector to be absorbed by the housing. The angle at which light departs a diffraction grating is based on its periodicity as well as the wavelength of light being used. This can be expressed by the following equation:

$$d \times (\sin(\theta_i) - \sin(\theta_m)) = m\lambda$$

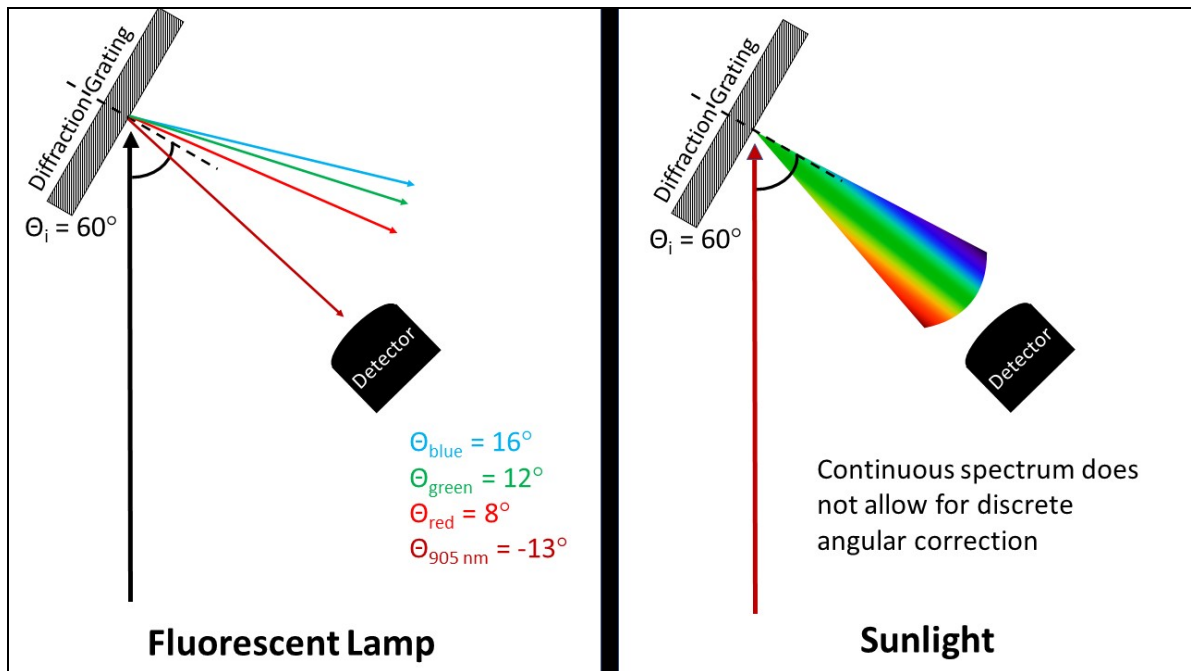
Where d is the distance between slits in a transparent grating or rulings in a reflective grating, λ is the wavelength of light interacting with the grating, m is a numerical integer representing the diffraction order, θ_i is the incident angle of incoming light, and θ_m is the diffraction angle of light corresponding to the m^{th} diffraction order. Rearranging the equation, we can find the m -ordered exit angle from the diffraction grating as a function of the wavelength, entry angle, and grating distance as follows:

$$\theta_m = \arcsin(\sin(\theta_i) - \frac{m\lambda}{d})$$

As such, it is feasible that we can angle this diffraction grating such that only 905 nm light is transmitted to the receiver, eliminating all extraneous light. The primary issues are those regarding the absorption of unwanted light and performance of the system in outdoor environments. Even in a fluorescent environment, where the most intense light of around 440 nm, 550 nm, and 615 nm experience an angular diffraction much different than our intended 905 nm signal's angle, scattering and reflections from the inside of the packaging of our system may result in a noisy signal still reaching the detecting, affecting our measurement of the 905 nm light unless the insides are specifically designed with this in mind.

Designing the inside of our device to reduce internal reflections may still pose issues in brightly sunlit environments. Because the diffraction grating imparts an angular direction based upon both grating and wavelength, there may be many wavelengths that are being directed to the detector based upon the spatial proximity of the detector to the diffraction grating and the spectral proximity of the wavelength to our intended wavelength of 905 nm. As we saw in the spectrum of sunlight, there are many of these wavelengths present with not-insignificant power that may affect our signal.

Figure 37: Diffraction Gratings {Kasap, 2013 #22}



This is characterized in the above figure. The relatively discrete emission wavelengths of a fluorescent lamp are able to be separated and directed away from the detector using simple angular and axial separation. In a limited space of only a few centimeters, the separation between our signal light at 905 nm and noise light from the fluorescents is enough for our detector to remain unaffected by ambient light. However, the issue of sunlit areas is readily apparent when we consider the sun as a broadband source, with comparable intensity of light with frequencies surrounding that of our signal light. Because of this broadband emission, it becomes impossible to separate entirely the ambient noise from our signal. As such, a large portion of the light reaching the detector would be from the sun and not from our ranging signal, ruining our SNR. The diffraction grating method is more suitable for indoor applications or those completely sealed from broadband light sources such as the sun.

The better option for combatting ambient noise is the implementation of a bandpass filter, as it is a simpler and more effective solution at a cost comparable to that of the diffraction grating. Bandpass filters serve essentially as optical density filters outside of their specified wavelength range, absorbing all radiant energy, while allowing a high percentage of bandwidth specified light to pass through. In the specific model we will be implementing, the filter's central wavelength is 905 nm and exhibits a 10 nm bandwidth. Visible and near infrared light outside of the bandpass range experience a -40 dB loss, while the light within the range experiences a 90% transmission.

As such, the bandpass filter will eliminate almost all of the unwanted light that could pose an issue with our silicon detector. Because it absorbs the unwanted light, we no longer have to worry about reflections and scattering that can occur with a diffraction grating. Additionally, this implementation will be far more effective in brightly sunlit areas due to its broadband effectiveness, something which the diffraction grating cannot do. Also importantly is the simplification of optical and packaging design needed to be performed, as the bandpass filter can be placed directly in front of the detector with no additional alignment or calculation required, unlike the diffraction grating solution. As such, and in consideration of the relatively negligible cost difference of \$30, we shall implement a bandpass filter into our design over a diffraction grating.

3.3.5 Timing

In order to digitize the inputs from our laser optical system and translate between the time and space domains, we considered using both analog-to-digital (ADC) and time-to-digital (TDC) approaches. We also considered digital down conversion (DDC) as a means to reduce our high-speed input signal to a lower sampling rate that can be more easily processed.

3.3.6 Microcontroller

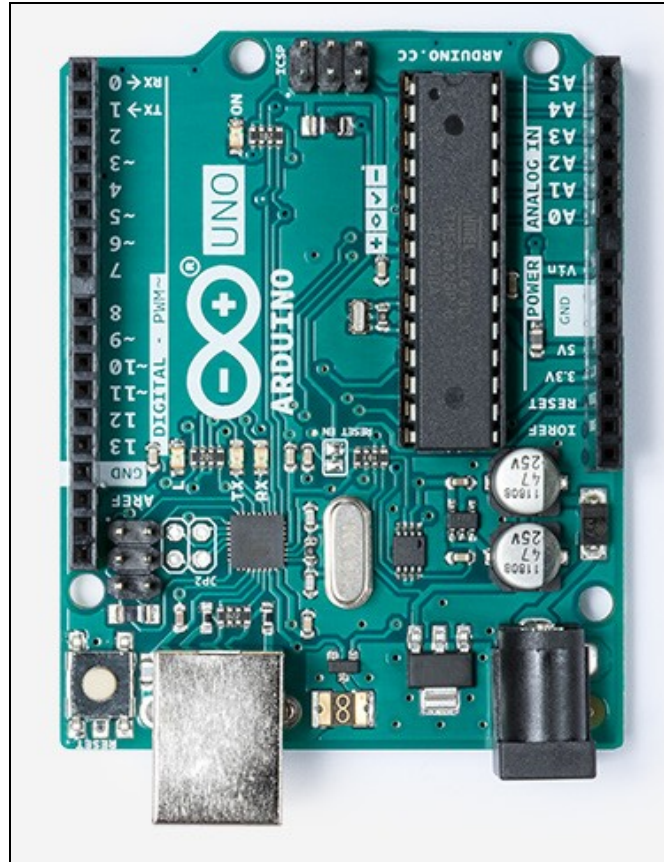
A microcontroller has a few advantages over other computing designs that make it desirable for this project. For starters, microcontrollers are low-powered and often have low-power modes that make them use even less energy when idle. This is important for reducing the size of the battery necessary for our project. A second advantage is that because we do not need really advanced software, peripherals and features, we won't pay for bloated computing architecture. We can devote the space, time and money that those additional features would require elsewhere to provide a more affordable solution. Lastly, because of their popularity in the market, microcontrollers today are well documented by a combination of manufacturers and hobbyists. This will help us to develop our prototype more quickly and test sooner before we deliver the final product.

To decide on a microcontroller model, we researched a few popular options used in the market today. Based on the amount of resources and documentation available on these models, we compared the Atmel, ARM and MSP430 microcontrollers. We looked for characteristics of speed, low power, memory size, communication protocols, and ease of use. Below are the results from what we found and which microcontroller we ended up using for this project.

Our first consideration was Atmel's AVR microcontroller that is used on many Arduino boards such as the *Uno*. Specifically, we looked at the ATmega328P 8-bit model. The Atmel architecture on the Arduino boards works very well

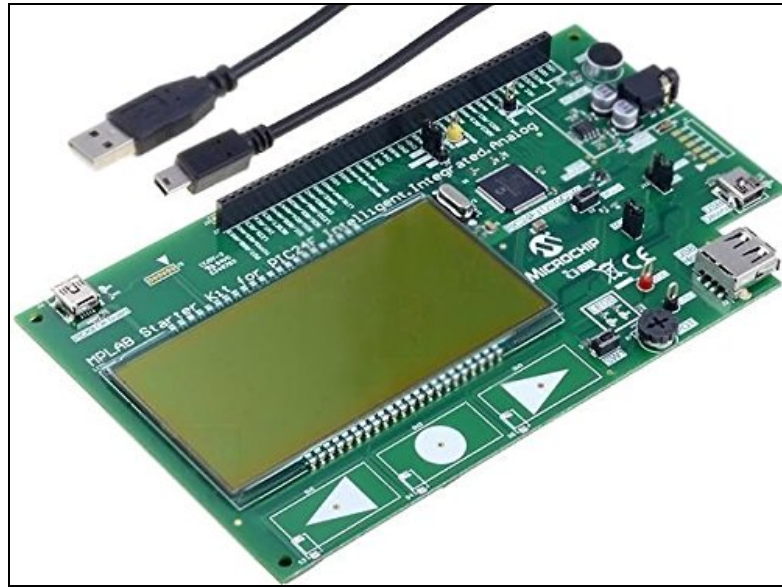
especially for hobbyists. Many who are new to microcontrollers tend to pick up an Arduino for its cheap cost, well-designed IDE software and reliability for projects. There is also a lot of support for the Arduino microcontrollers online.

Figure 38: ATmega328P on an *Arduino Uno* (Permission requested)



Second, we considered a product line from MicroChip called the PIC microcontroller. Based on the Harvard architecture design (separated code and data segments), PIC is also popular with hobbyists because of its cheap price, a plethora of documentation, and affordable or free access to PIC development tools. While there is not a dedicated board for each microcontroller, the parent company MicroChip sells development boards that fit many of the models. One of our team members has some experience with these microcontrollers and many online sources recall a similar experience: the PIC microcontrollers are not very forgiving and can be difficult to use.

Figure 39: PIC24FJ128GC010 Microcontroller (Permission requested)



Finally, quite possibly the most popular microcontroller, the MSP430 is a well tested and used chip. With many hobbyist contributions and documentation online, the MSP430 is well supported and is one that we have the most prior experience with. Texas Instruments provides affordable development boards called Launchpads which connect to a PC via USB and are programmable via their IDE software Code Composer Studio. Our team, especially our programmer, has the most experience with this board. With many GPIO pins and Booster Packs available to purchase, there are many ways to load up the MSP430 with peripherals. Our team, especially our programmer, has the most experience with this board and we believe this will be the best choice for our project.

Figure 40: MSP430F5529 LaunchPad (Permission requested)

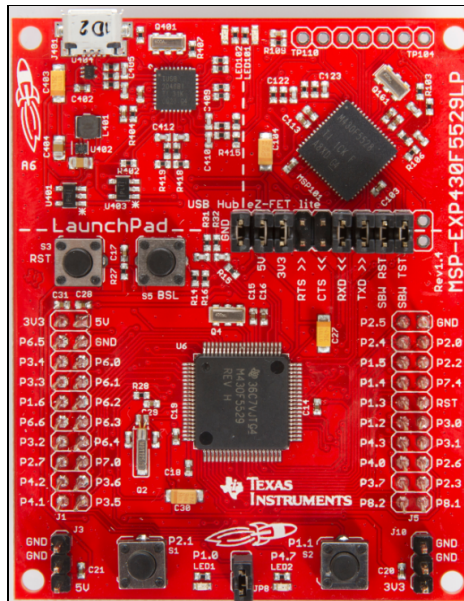


Table 17: Microcontroller Comparisons

	ATmega328P	PIC24FJ128GC010	MSP430F6459
Architecture	8-bit	16-bit	16-bit
Program Memory Size (KB)	32	128	512
CPU Speed (MIPS/DMIPS)	20	16	--
Max CPU Speed (MHz)	--	32	25
SRAM (Bytes)	2,048	8,192	66,000
Digital Communication Peripherals	1-UART, 2-SPI, 1-I2C	4-UART, 2-SPI, 2-I2C	2-UART, 4-SPI, 2-I2C
Capture/Compare/PWM Peripherals	1 Input Capture, 1 CCP, 6PWM	9 Input Capture, 9 CCP, 9 PWM	12 CCP

Direct Memory Access Channels	6	6	3
Timers	2 x 8-bit 1 x 16-bit	14 x 16-bit 4 x 32-bit	4 x 16-bit
Temperature Range (C)	-40 to 85	-40 to 85	-55 to 150
Operating Voltage Range (V)	1.8 to 5.5	2 to 3.6	1.8 to 3.6
Pin Count	32	100	100
Price (\$USD)	1.46	3.85	6.48
Expected Ease of Use	7	4	8

3.3.7 Power Source

In order to power our device we require a mobile power source which can provide up to 12 hours of power under typical operating conditions. This will allow our users to operate our product continuously throughout the course of a day and charge it at night. We considered several battery technologies when choosing a power source for our project, and compared their advantages and disadvantages to determine which would be best suited for our device.

We began by considering the battery technologies which are most commonly used in mobile devices. These include lithium ion and lithium polymer, nickel cadmium and nickel hydride, and lead acid. The main considerations as per our design constraints were weight and, by extension, energy density. Our device would require a power source which packed as much energy into as small a format as possible while not becoming cost prohibitive.

Since energy density was one of our primary concerns, lead acid proved to be a poor choice. While relatively cheap and capable of providing high levels of current, they do not pack the energy density needed for our device. Comparing the specific energy of lead acid batteries, 30-50 Watt-hours per kilogram, to that of lithium ion batteries, 110-160 Watt-hours per kilogram, shows that the trade-off between density and cost is simply not worth it in the case of lead acid batteries. It should also be noted that lead toxicity is a concern when it comes to environmental and health concerns, but this is of more importance when considering manufacture and disposal than user interaction.

Moving on to lithium ion and lithium polymer batteries, we see that the two technologies are very similar. Lithium polymer technology will provide a slightly slimmer and simpler packaging. The trade-off, however, is increased cost and a slightly less competitive energy density of 100-130 Watt-hours per kilogram compared to lithium ion. Several other advantages of lithium ion that bear mentioning are that they do not require priming when first used nor do they suffer from significant self-discharge. While lithium ion batteries do age even while not in use, this will not be a serious concern for our project since the battery will not go for extended periods without use under normal operating assumptions. Finally, although lithium ion batteries have very low overcharge tolerance and must be monitored to ensure they remain within safe operating conditions, the circuitry to achieve this is well-studied and not difficult to implement.

Finally, nickel cadmium and nickel hydride both have lower specific energies than lithium ion, coming in at 40-80 and 60-120 Watt-hours per kilogram, respectively. Nickel cadmium has the advantage of being rugged and extremely economical, which the best ratio of charge cycles to cost of all the batteries we considered. However, it's relatively low energy density makes it too cumbersome for our application. Meanwhile, nickel hydride boasts better energy density characteristics but lacks the ruggedness and cost effectiveness of nickel cadmium. In fact, nickel hydride is the most high-maintenance of the battery technologies under consideration, requiring regular full discharge so as to prevent the formation of crystals, as well as needing very particular charge and discharge cycles to prevent performance deterioration. Even under ideal conditions, nickel hydride batteries tend to wear out too quickly and their special requirements simply impose too many design constraints for a battery technology which is barely competitive with lithium ion in terms of energy density.

Thus, the best choice of power source for our design is the lithium ion battery. Its high energy density provides sufficient power for the operation of our diode, microcontroller, and other electronics within a compact form factor, allowing our device to meet our 12 hour maximum runtime target without being too cumbersome to the user. The lithium ion battery has the additional advantage of a low self-discharge rate relative to other battery chemistries, as well as not requiring any priming or maintenance in order to function properly. While lithium ion batteries have a greater cost per cycle than alternative battery technologies such as nickel cadmium or alkaline, the cost difference is not prohibitive and the energy density advantage is too good to pass up.

3.4 Purchased Components

Below is a breakdown of all of the components that were chosen to be integrated into our system and an image of all the components currently in our possession for our device.

Figure : Purchased Major Components (No permission needed)



Table 18: Purchased Hardware Components

Item	Part	Description
1	LJ1402L1-B	f = 40.00 mm, H = 10.00 mm, L = 12.0 mm, N-BK7 Plano-Convex Cylindrical Lens, Antireflection Coating: 650-1050 nm

2	LJ1942L1-B	f = 12.70 mm, H = 10.00 mm, L = 12.0 mm, N-BK7 Plano-Convex Cylindrical Lens, Antireflection Coating: 650-1050 nm
3	FL905-10	Ø1" Laser Line Filter, CWL = 905 ± 2 nm, FWHM = 10 ± 2 nm
4	L904P010	904 nm, 10 mW, Ø5.6 mm, A Pin Code, Laser Diode
5	LM317	Voltage Regulator
6	iC-Haus Linear CMOS	CMOS Sensor Array
7	MSP430F6459IPZR	Microcontroller
8	DRV2605LDGSR	Haptic Driver
9	ADC3244IRGZT	Analog-to-Digital Converter
10	Adafruit 1201 Actuator	Eccentric Rotating Mass Actuator
11	TS5A12301EYFPR	IC Switch

4. Related Standards and Realistic Design Constraints

This section details the standards used in the design process of the project. These engineering standards help ensure quality, reliability, and execution of the project goals. This section shall also examine the constraints which will impact our project.

4.1 Related Standards

Standards are used as a means of communication in Engineering. Standards establish baseline requirements when we choose to design, test, and create products. Standards are shared across the globe as a way to ensure quality, reduce costs, and most importantly keep the public safe. When engineers choose to deviate from standards established by professional groups or committees the result is a financial catastrophe such as building codes in Florida.{Allen, 2018 #25} Standards ensure compatibility between hardware and software and facilitates integration. Another example that comes to mind is building standards in the panhandle of Florida. The loose old building standards resulted in a lot of home destruction and loss of lives after Hurricane Michael. If construction companies had applied the most up to date building standards of storm shutters and reinforced concrete block construction, lives could have been saved.{Allen, 2018 #25} These examples emphasize the real value of standards even though they cannot always be enforced. Without standards, we could not have consistency for products, systems, and processes.

For our project, the main standards involved electronics and lasers. The electronic standards were important because they ensure that our device is capable of being safely and effectively operated by its users. By complying with electronic standards, we can ensure that the device is compatible with existing electrical infrastructure and does not pose a risk of harm to users and bystanders when used properly.

The laser standards were important because lasers pose the risk to potentially blind people if used incorrectly. Not much power is required from a laser to permanently blind somebody due to the sensitivity of the retina. By adhering to these standards we have researched, we can ensure that our product minimizes risk to the public while being of great use to the blind.

The majority of the standards used in this project came from IEEE and ANSI. IEEE stands for the Institute of Electrical and Electronics Engineers and ANSI stands for the American National Standards Institute. Both of these groups create the standards used in industry to ensure performance capabilities. These

groups were selected because the target population we wish to serve with our product is located in America.

4.1.1 Laser Standards

The standards researched for our project are listed below. The standards were implemented in the design and prototype for our project to ensure product quality. Our project components include a laser, electronics, CMOS camera, power, microcontroller, and software.

- **ANSI Z136.4** - Recommended Practice for Laser Safety Measurements for Hazard Evaluations - provides information on how to measure, classify, and evaluation optical radiation hazards.
- **ANSI Z136.6** - Safe Use of Lasers Outdoors -provides guidelines for laser usage in outdoor environments
- **ANSI Z136.7** - Testing and Labeling of Laser Protective Equipment - provides information on test methods and protocols for required eye safety glasses
- **IEC 60825-1:2014** - “Safety of laser products Part 1: Equipment classification and requirements”
- **21CFR 1040.10** – “Performance Standards for Light Emitting Products (Laser Products)”

Lasers can be broken up into four hazard classes (1, 2, 3a, 3b, and 4) depending on the potential to cause eye damage or inflict thermal burns. The classification based on ANSI Z136.1 standard classifies lasers based on a combination of calculations including exposure time, laser wavelength, and average power for continuous wave or repetitively-pulsed lasers and total energy per pulse for pulsed lasers. A chart distinguishing and describing the classifications can be seen below.

Table 19: Laser Classifications {ANSI, 2018 #26}

Laser Classification	Description
Class 1	<ul style="list-style-type: none"> ● Low power and safe under all conditions of normal usage
Class 2	<ul style="list-style-type: none"> ● Low power sources ● Wavelength range of 400 nm - 700 nm (visible wavelengths) <ul style="list-style-type: none"> ● Power < 1 mW ● No hazard if exposure < 0.25 seconds due to reflex

	reaction of the human eye
Class 3R	<ul style="list-style-type: none"> • Wavelength Range 302.5 nm - 10⁶ nm • Power between 1 mW - 5 mW
Class 3b	<ul style="list-style-type: none"> • Medium power laser sources • Power between 5 mW - 500 mW • Dangerous if exposure is longer than 10 seconds and eye is within 13 cm from the light emitting source
Class 4	<ul style="list-style-type: none"> • High power visible and invisible wavelengths • Can cause damage to eye and skin • Power output is generally above 500 mW

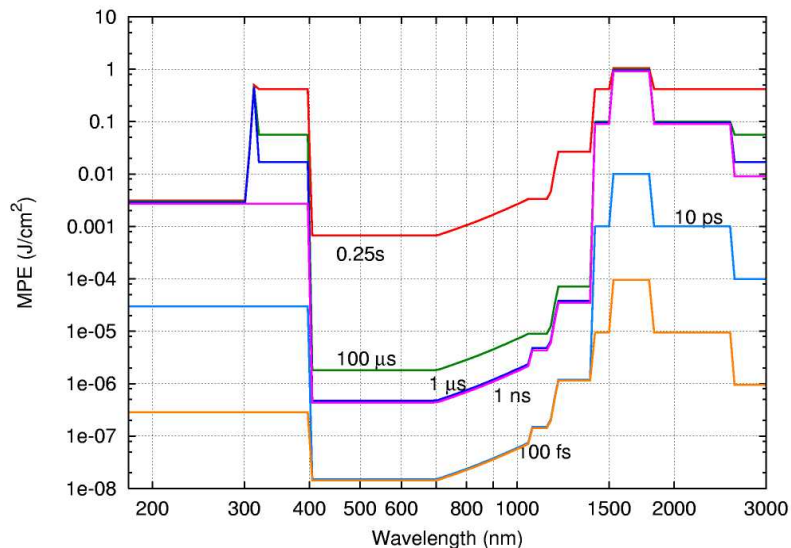
4.1.2 Design Impact of Laser Standards

After understanding the laser standards, the calculations help define a factor called the Accessible Emission Limit (AEL) which is the product of the maximum permissible exposure (MPE) limit and an area factor called limiting aperture (LA) which can be seen in the equation below{, 2018 #27}:

$$\text{AEL} = \text{Maximum Permissible Exposure} * \text{Area of Limiting Aperture}$$

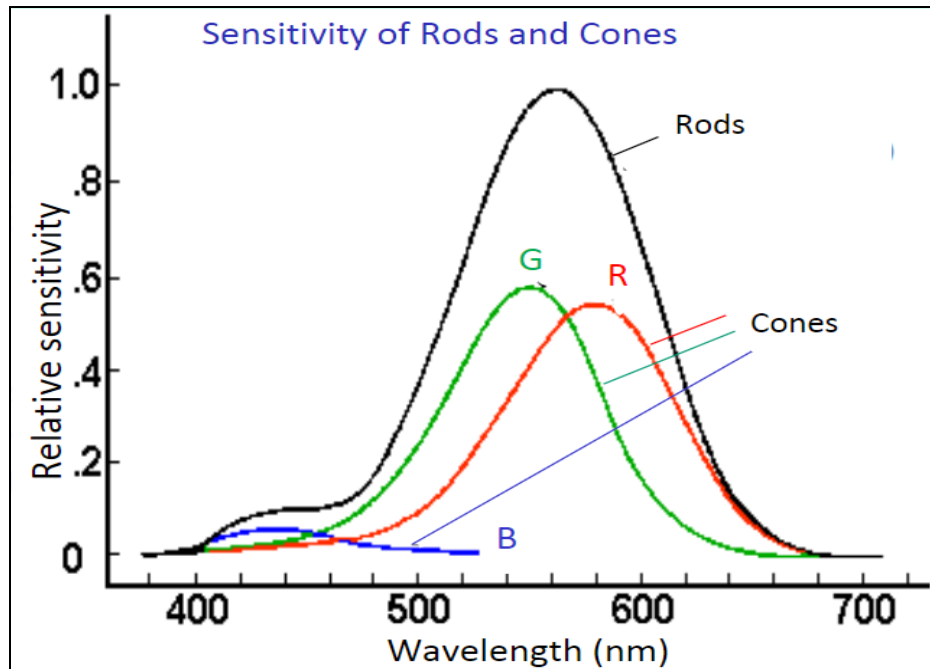
The maximum permissible exposure standard IEC 60825 essentially defines how long a person can be exposed to a collimated beam focused directly onto the retina. A graph explaining the relationship between maximum permissible exposure, wavelength, and exposure time can be seen in the figure below.

Figure : 41 MPE Vs Wavelength (Permission Requested)



Furthermore, confirmation that our product will be safe with the use of our product is this figure depicting the absorption spectrum of the eye. Due to the nature of rods and cones high sensitivity to visible wavelengths, the laser diode wavelength we have selected for our project lies in the near infrared regime. This will ensure that our product does not cause harm to the public.

Figure 42: Eye Sensitivity Spectrum (Permission Requested)



4.1.3 Software Standards

For our software development lifecycle, we are required to adhere to the ISO/IEC 12207 standard. {Standards, 2017 #28} This standard covers the development and maintenance of software systems and is the primary standard used in the industry.

One of the major particulars of this standard is the emphasis on standardizing the *processes* and not the *stages* of software development. A stage is defined in the standard as “period within the life cycle of an entity that relates to the state of its description or realization”. A process is defined as a “set of interrelated or interacting activities that transforms inputs into outputs”. The differences between the two is important because there are so many different developers from different backgrounds in different industries and the way they develop may be different but they all should follow the same types of *processes*.

There are four processes outlined in the standard: Agreement Process, Organizational Project-Enabling Process, Technical Management Process and Technical Processes. Not all of the processes need to be implemented (Full Conformance). This standard gives guidance for a customized development cycle (Tailored Conformance). Below are the four major processes and the structures which they provide the development life cycle.

First, the Agreement Process requires that the development team come to an understanding with the customer about what is being asked, what is required, how it will be acquired, etc. Any questions involving initiating the project should be asked in this first process. From our research and conversations with Accessibility Services and industry professionals, our team determined the needs and requirements needed from the software in our device to provide the proper functionality.

Second, the Organizational Project-Enabling Process is needed to handle the infrastructure of resources. A development cycle needs defined life cycle model management, infrastructure management, portfolio management, human resource management, quality management, and knowledge management processes. These resources in place will help the development entity with the start, development, and support of the system over its lifetime. Our team discussed how we will allocate the work and what resources will be required to accomplish the task.

Third, the Technical Management Process involves the handling of the software during its entire life cycle. A project like this will require Project planning, Project assessment and control, Decision management, Risk management, Configuration management, Information management, Measurement, and Quality assurance.

Fourth, the Technical Process is the largest, including fourteen unique processes including Business or mission analysis, Stakeholder needs and requirements definition, Systems/Software requirements definition, Architecture definition, Design definition, System analysis, Implementation, Integration, Verification, Transition, Validation, Operation, Maintenance, and Disposal. Throughout the whole life cycle of the software, these processes will help support the development personnel and ensure that the delivered software meets customer requirements, industry standards, and long-term support required.

4.2 Realistic Design Constraints

Standards ensure that the products we use are safe and reliable. There are numerous regulatory agencies in the United States responsible for overseeing various aspects of the development and compliance of national standards.

For example, the Consumer Product Safety Commission (CPSC) is authorized to protect the public “against unreasonable risks of injury associated with consumer products” and to that end has developed uniform safety standards for consumer products. Since our device is meant for consumer use, we must ensure that it meets these safety standards. The CPSC also takes a special interest in protecting the health and safety of children’s products, which it defines as “a consumer product designed or intended primarily for children age 12 years or younger”. Because our device is not primarily intended for children under 12 years of age, but rather for all people with visual disabilities, regardless of age, we will not need to adhere to these restrictions, although they may be taken as useful guidelines for general safety.

An additional set of national standards which are devoted more specifically to electronic devices is the UL 60950-1 Standard for Safety for Information Technology Equipment. This is an ANSI approved standard which covers numerous aspects of device electronics design, from general principles of safety to specific electrical and physical requirement. Of particular interest to our project are the sections of circuit design and thermal and materials constraints.

4.2.1 Economic and Time Constraints

Economic constraints such as the team being working college students limited the budget of quality components purchased. The largest area where the budget impacted the project can be seen in the Optics purchased for the project. Electronic components are far cheaper than optical components. The main reason why is optical components also require custom machined mounts to hold the optics in place which can result in overspending of the allocated budget. Adding onto the nature of the project to use eye-safe lasers resulted in custom coated Optics to work in the near-infrared regime. The team overcame this challenge of purchasing optical mounts by working together to develop a 3D printed housing in which the optics can be seated as well as all the associated electronic components. Through careful design, the team was able to ensure that the optical system was optimized for performance and had a tight fit into the opto-mechanical housing to prevent loose Optics. This was critical because the visually impaired person using the product would be constantly moving and scanning.

Another economic constraint for this project was to develop a product a visually impaired person could afford. As examined in the research section about current products that exist, a majority of them can’t reach the market due to the price tag. The device created is not necessarily cheap by any means, but the value can be seen in the performance of the device. It is also important to note that the device is a prototype. Further iterations of the prototype and fine-tuning can lead to the price of the product going down. The device performs at the same high standards as comparable products at a fraction of the cost.

The time constraints for this project involved design, purchasing, testing, and integration of the device within the span of two semester. After a period of forming the team, the team was left to execute immediately after initial research phase on the needs of the visually impaired were understood. The challenge for this project was a late pivot from LIDAR to laser triangulation as the range finding technique. Overall, the team was able to adjust accordingly, but additional time and resources would have given the opportunity for the team members to improve the project. One stretch goal for the project is to implement a location module on the project to allow certain paths visually impaired people take to be saved. This would be useful since many visually impaired people rely on patterns when they travel. The location module would also help the visually impaired orientate themselves in the direction they need to travel in. The module could also be used for tracking so that family and friends can check up on their visually impaired loved one at any given moment and give peace of mind.

4.2.2 Environmental, Social and Political Constraints

The environmental constraints of the project included where the device was ultimately going to be used by the visually impaired. The outside environment vs the inside environment were both considered in the design of the device with the usage of the bandpass filters to allow the device to be used in both settings. In addition, the types of objects the visually impaired will encounter changes with the environment they are in. As long as the visually impaired person is not in an environment consisting of a lot of glass walls the device should function properly. It is also important to note that the device designed is not a stand alone, but a supplement to the tools the visually impaired already use when navigating their environment with a white cane. The device is eye-safe which allows it to operate in the outside environment without worrying of harming others.

The social constraints for this project involved designing a product which would not bring attention to the visually impaired person using the product. In our meeting with Brad Held and Heather Willenbacher of UCF Student Accessibility Services, we learned that people with visual disabilities preferred using inconspicuous aids so as to avoid the social stigma which might follow from having a disability in public. A majority of visually impaired people want to simply blend in and avoid bringing attention to their disability, so it is critical that the product integrates seamlessly into normal clothing with minimal disruption in daily social contexts.

Existing government regulation regarding mobility and orientation aids were of primary concern when considering the political constraints of our project. The Americans with Disabilities Act was passed in 1990 and was updated as recently as 2010 to reflect changes in orientation and mobility aids. However, the primary

focus of this legislation regarding aids, even in its updated forms, has been ensuring accessible infrastructure which does not inhibit the users of mobility aids from travelling freely. As such, these regulations concern themselves mostly with building regulations to enable the unencumbered use of motorized mobility vehicles by persons with disabilities. As such, there does not currently exist specific regulation for electronic orientation aids such as our device outside of the more general regulations for consumer electronic devices. This was verified in our meetings with Student Accessibility Services. A point of future research as regards political constraints might be the use of government grants to help disabled persons purchase for our device, although such consideration would be premature at this point in the design process. {ADA, 2010 #29}

4.2.3 Ethical, Health & Safety Constraints

The purpose of the project was to develop a device which helped the visually impaired people navigate their surroundings with confidence by detecting objects. As a core component of the device involves an infrared laser, health and safety of the public could not be understated. Calculations were performed multiple times and verified to adhere to the laser safety standards as well as consultations with faculty members. Rigorous testing of the optical power was also measured using the power meter. If an individual with normal vision becomes blind due to encountering a visually impaired person using the device then the project has failed to meet the objective to keep everybody safe. The group members of the project would be held responsible for the damage done. For these reasons, the prototype was tested and evaluated in a secure environment before it was brought out for usage in a public setting.

4.2.4 Manufacturability and Sustainability Constraints

A key consideration when taking on this project to develop a visual aid for the blind to navigate their environment was to create a product which could eventually be produced on a mass scale. The manufacturing constraint which impacted this project the most was packaging everything in a manner which was compact for the laser triangulation system. The device could not exceed a certain weight and size dimension. Furthermore, the laser triangulation system is a calibrated device so all the parts need to be in the correct location.

The optical housing which was custom-made and 3D printed improves how many of these devices can be manufactured at any given time due to the increase in accuracy and precision. It could easily be seen in the future with the correct amount of parts that the device could be made in batches. A simple manufacturing process plan could be generated telling where the electronics and associated Optics would fit in their designated locations. The material used to encase the device is very robust and would be able to handle harsh

environments. The only factor which impacts the sustainability of the device is the lifetime of the laser diode. The laser diode is not necessarily an easy component an everyday consumer would be able to solder on and replace. The device would need to be sent back to be repaired according to the lifetime hours of the laser diode used in the device.

5. Project Hardware Details

The project hardware detail outlines the design schematics as well as how the optimal components selected were integrated into the system for the project. The hardware diagram can be broken down into two main components involving electronics and optoelectronics. The electronic hardware side involved powering the MCU, CCD/CMOS detector, and feedback output (audio, haptic, etc...) to the user. The optoelectronic hardware side involved designing a laser diode driver and an electronic switching circuit to pulse the laser diode. An evaluation of different design schematics for different techniques were conducted to understand which design would help best fulfill the requirements of the project to develop a visual aid which enables visually impaired people to navigate their environment. The selected schematic chosen to best meet the project requirements was a laser triangulation system.

5.1 Initial Design Architectures and Related Diagrams

Below are diagrams outlining the total system and subsystems designed in this device.

Figure 43 : System Block Diagram (Permission not needed)

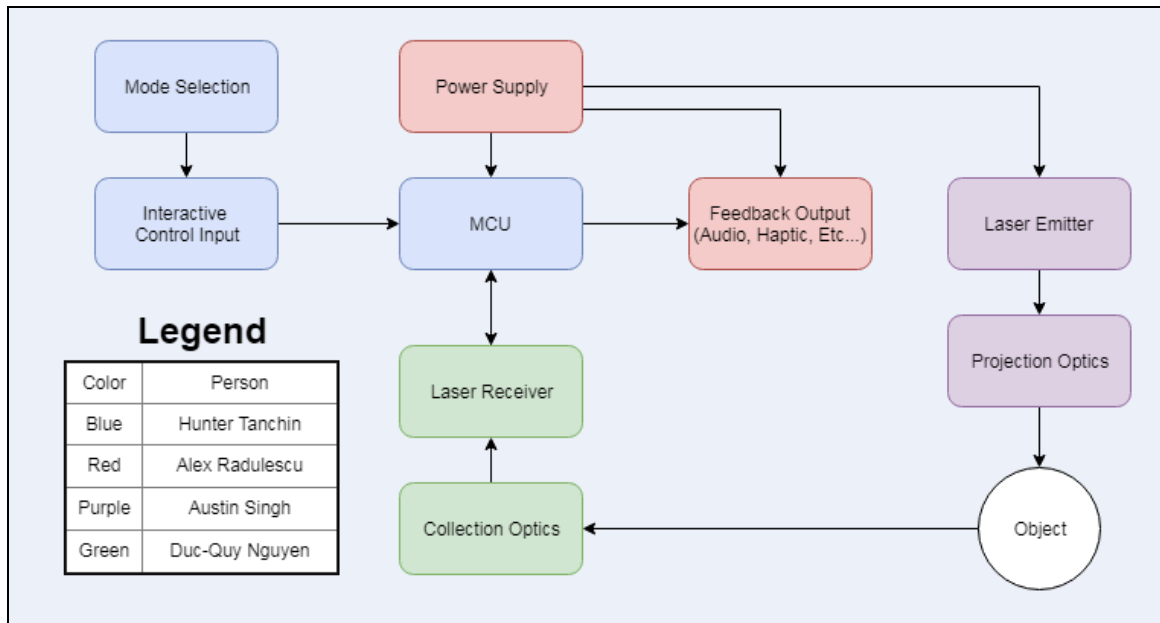


Figure 44: Software Flow Block Diagram (Permission not needed)

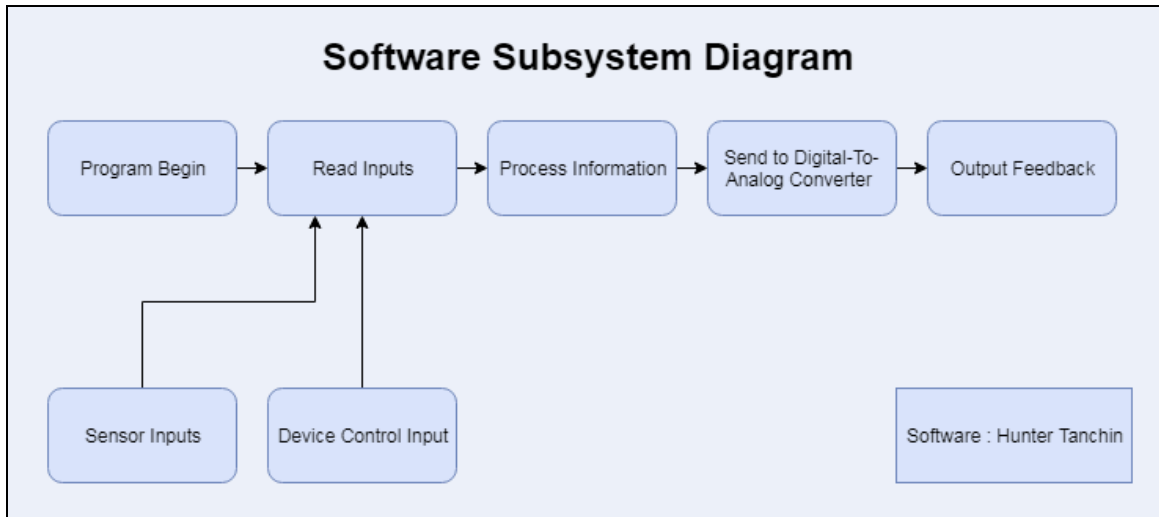


Figure 45: Optics Flow Block Diagram (Permission not needed)

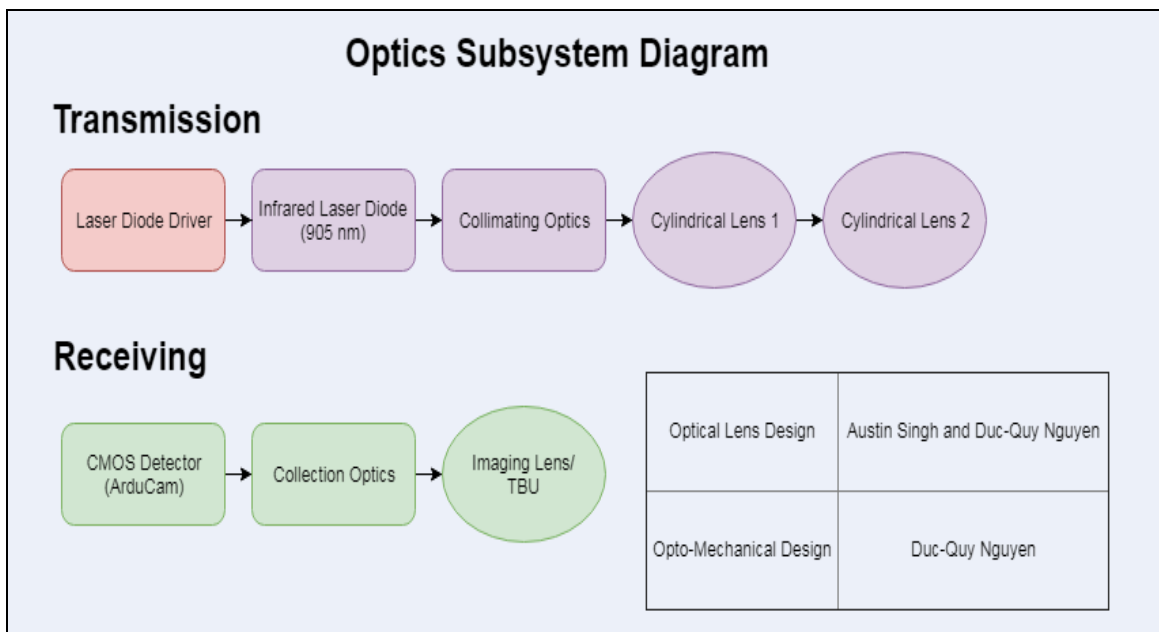
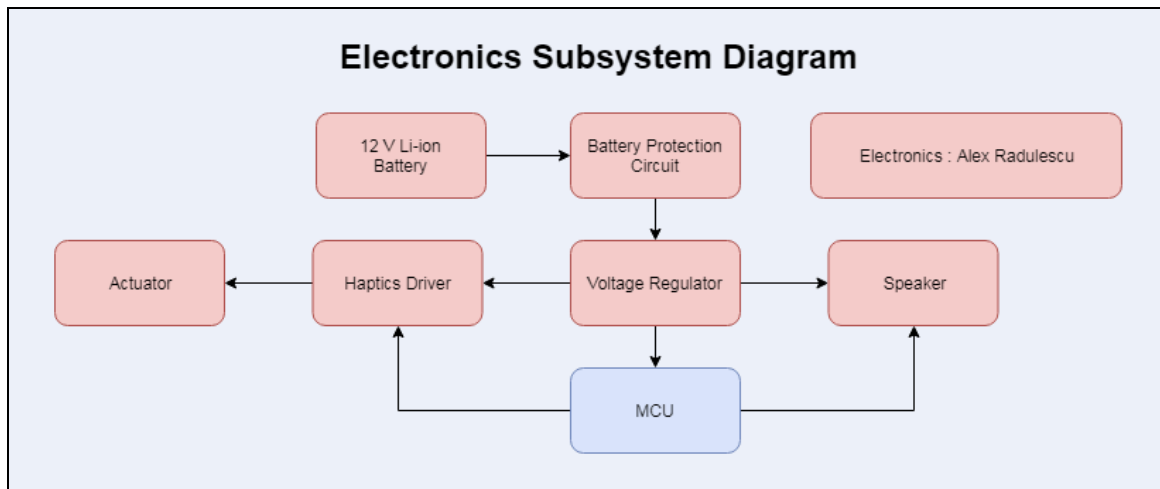


Figure 46: Electronics Block Diagram (Permission not needed)



5.2 Laser Transmitter

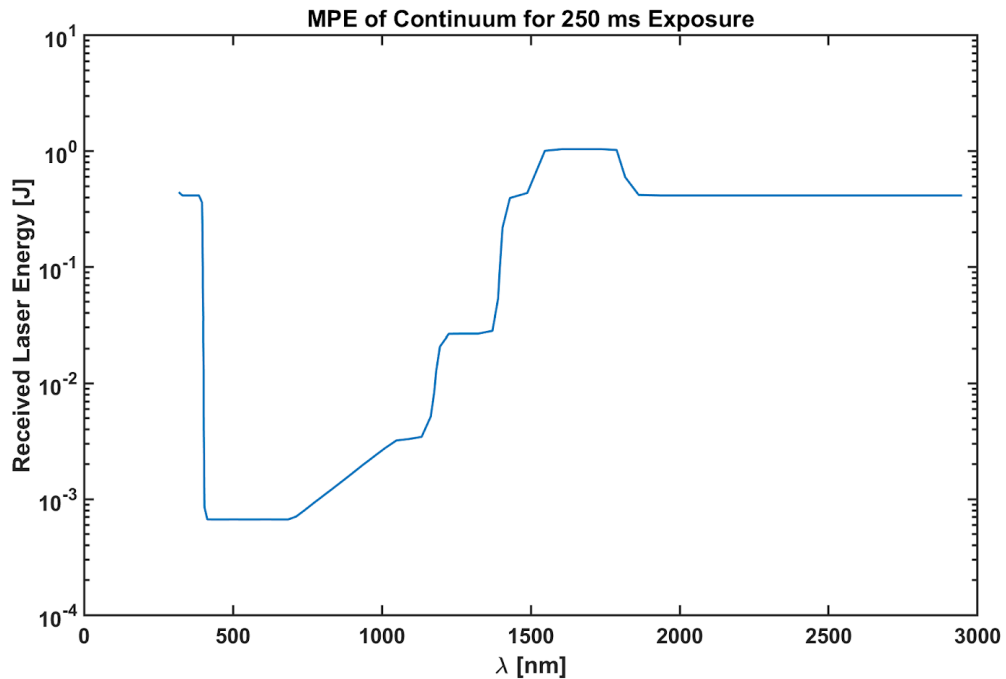
The design side of the laser transmitter for the laser triangulation system involved using a purchased off the shelf laser diode from Thorlabs with a 905 nm wavelength. In addition, a laser diode driver was developed using the LM317 component from Texas Instruments to serve as a constant current source. A rheostat was used as a variable resistor to test the output power as a function of current. The switching aspect to pulse the laser diode was done using

5.2.1 Power Considerations

Our laser diode is one of the most critical components of our system. In order to select the product and determine its functionality, we must carefully consider a multitude of factors. The most important of these aspects is the output power of our diode. Determining an appropriate operational power will produce a device that is both completely safe for general use as well as highly effective and functional.

The foremost concern we shall focus on is safety. As is discussed in our standards section, laser products are classified by ranking, according to how dangerous or harmful that laser product may be to humans. This ranking is based off of the most easily laser-damaged human tissue, which is the eyes. In order to produce a system that is eye safe, we should take into consideration when choosing a laser source the wavelength and what the maximum permissible exposure (MPE) energy to the eye is. From the IEC-60825 International Standard on the safety of laser products, we can determine the MPE of a wide continuum of wavelengths to help determine our product. The figure below summarizes this data.

Figure 47: 250 ms Exposure Energy Graph (No permission needed)

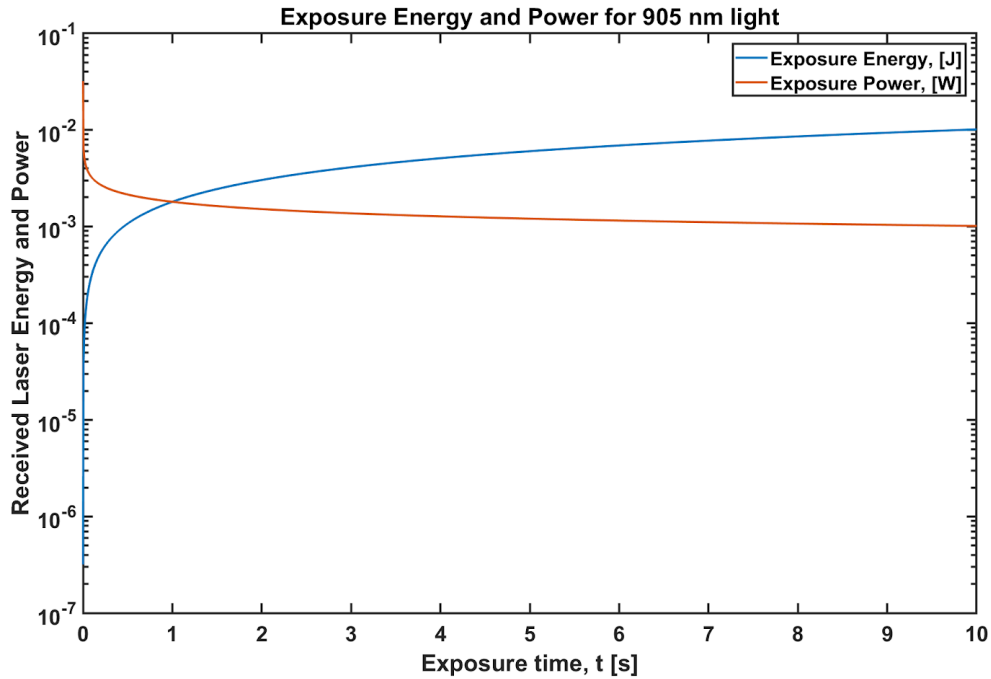


From this data we can see that wavelengths in the visible range are absorbed greatly by the eye, which eliminates them as potential candidates for our system. The highest MPE energy for a wavelength occurs between approximately 1500 nm and 1750 nm. Another suitable wavelength would be at approximately 1310 nm, because the MPE for that wavelength is also greater than an order of magnitude greater than that of visible wavelengths. Additionally, sources for these wavelengths are commonly available due to their ubiquitous presence in the communications industry. However, as discussed in a previous section, they pose an extremely high expense not due to the cost of laser sources, but the cost of photodetectors. To detect light in this near-infrared range, detectors are commonly made of InGaAs, which pushes the cost of individual photodiodes into the hundreds of dollars range, with pixel arrays costing several thousand dollars.

For this reason, and to still deliver a product that will operate both safely and cost effectively, our best choice for a laser source is from the 905 nm range of wavelengths. These wavelengths, while close to visible light, still absorb and damage less than visible light does, allowing for higher MPE energies. The sources are also as cheap or cheaper than those of 1310 nm or 1550 nm light. They also have the added benefit of greatly interacting with silicon, the cheapest and most common semiconductor available, resulting in a greatly lowered system cost compared to using a communication wavelength. If we are to use a

905 nm source, we must calculate the MPE to generate a Class I laser product, which is firmly eye-safe. This calculation, again taken from the IEC-60825, can be seen in the following figure.

Figure 48: Laser Exposure Energy and Power (No permission needed)

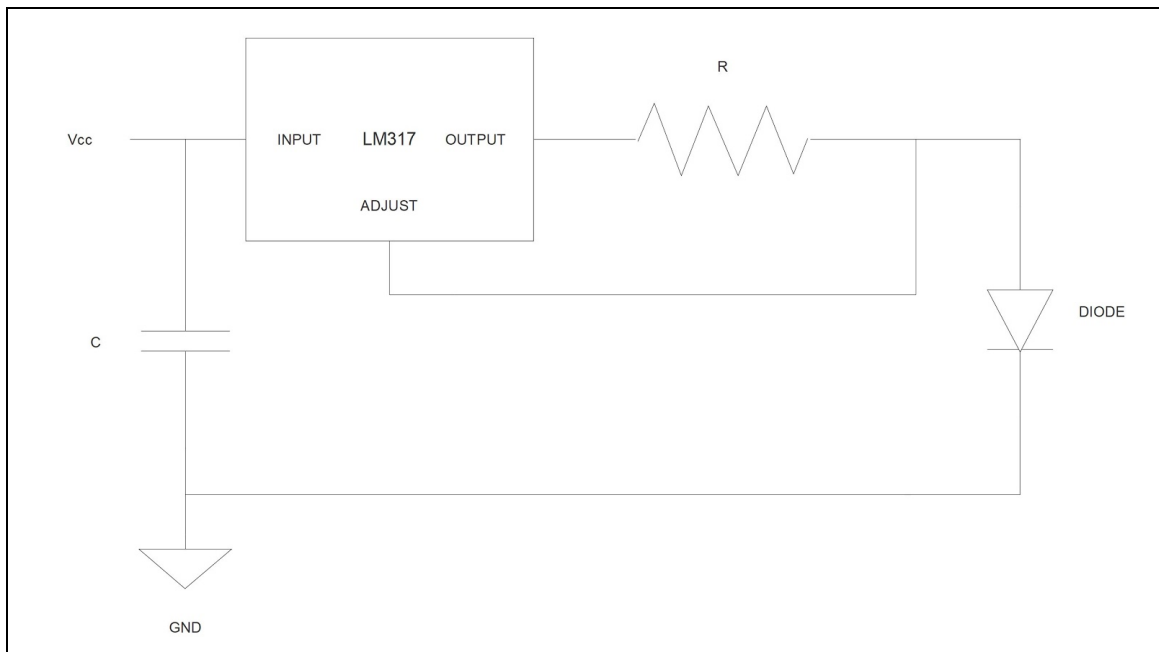


From these results, we can see that with a 1 second exposure, a Class I laser product operating at 905 nm can deliver up to 1.8 mJ of energy to the eye, or 1.8 mW of power. This is somewhat low, so we would like to use a shorter exposure time in our system in order to deliver higher power to our detector. At 250 milliseconds, we can deliver approximately 2.5 mW of power, and at 100 milliseconds, we can deliver up to 3.2 mW of power. Combined with strong filtering and a highly responsive silicon detector, powers on the order of 3.2 mW may be enough to successfully perform our detection. The limitation on the maximum power we can use lies in the temporal length of the emissions we generate, and the speed at which we can capture the power incident on our detector in order to maintain our device as a Class I laser product.

5.2.2 Diode Driver

The method involved for controlling our laser diode involved a constant current source. The schematic for this circuit can be seen below:

Figure 49: LM317 Constant Current Laser Diode Driver Schematic (No permission needed)



The LM317 is an adjustable three-terminal positive-voltage regulator with several possible applications, including as a precision current limiter. This application, which we used in our design to ensure a constant current source for our diode, requires a fixed resistor between the output and adjust pins of the LM317. The resulting current through the diode is given by dividing a voltage of 1.25 V by the resistor value R.

$$I_{diode} = 1.25 \text{ V} / R$$

Our design requires a current through the diode of approximately 50 mA. Solving for R results in a resistor value of 25 ohms. The input capacitor is recommended by the manufacturer to provide sufficient bypass and a value of 0.1 microfarads is used.

Why does our laser diode require a constant current source? The main reason why our laser diode requires a constant current source is any instability in the driving current such as it fluctuating can directly impact the performance characteristics of our laser diode. A consistent laser beam spot size with a constant intensity is critical for our system to be able to detect and image.

If the laser does not receive enough current then it will be below threshold meaning no lasing will occur and our semiconductor will act as an LED. If the current is far too high on our device then this will fry the laser diode. Maintaining a constant driving current ensures our device is operating in the most efficient

manner. In addition, it is critical to have the correct current driving the laser diode because the switching circuit on the electronic side to generate the laser pulses depend on it. The current running through the laser diode and the electronic switching circuit ensure the device is maintaining compliance of being eye-safe.

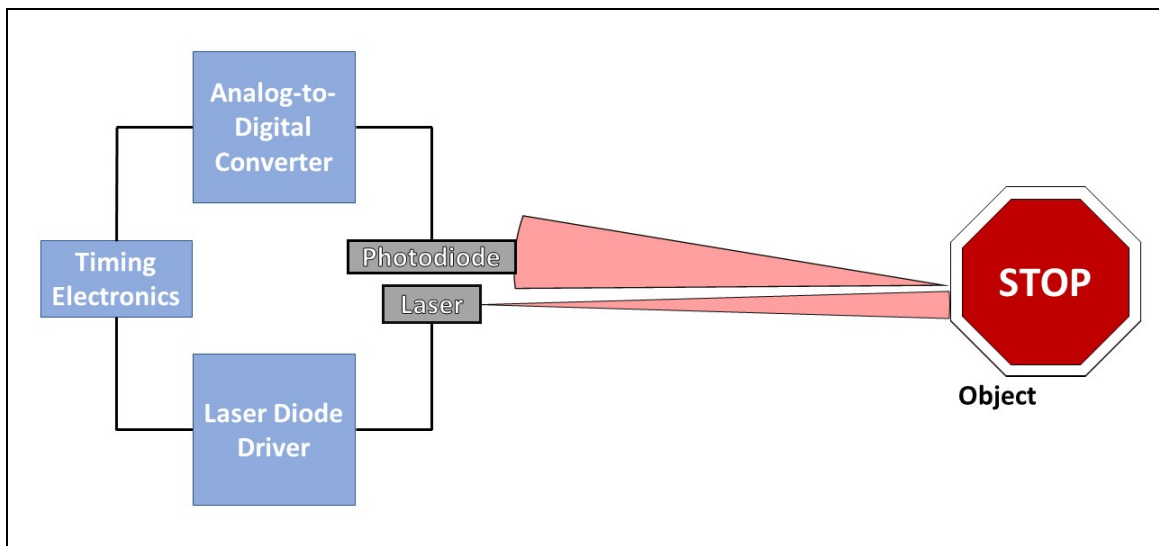
5.3 Optical Configurations

The optical configurations of LIDAR and laser triangulation were examined in this section. The reason for this being that the optics involved in LiDAR and laser triangulation overlap as well as some of the electrical components. In addition, a tight examination of both system ensures that the method of detection chosen for the project is correct.

5.3.1 LiDAR, Electronic t_0

The initial technology that we were planning on implementing into our design was time of flight LiDAR. Many common LiDAR systems, such as those used in golf rangefinders and laser tape measures utilize what is known as a monostatic biaxial system. Monostatic refers to a singular, unchanging plane upon which the signal travels, while biaxial refers to the two axes that the signal travels upon in the plane of the ranging system. This system essentially places the photodetector and laser diode axially near one another, using the divergence and scattering of the beam to receive the signal back on the detector. This system is illustrated in the figure below.

Figure 50: LIDAR (Electronic t_0) System Diagram (Permission not needed)



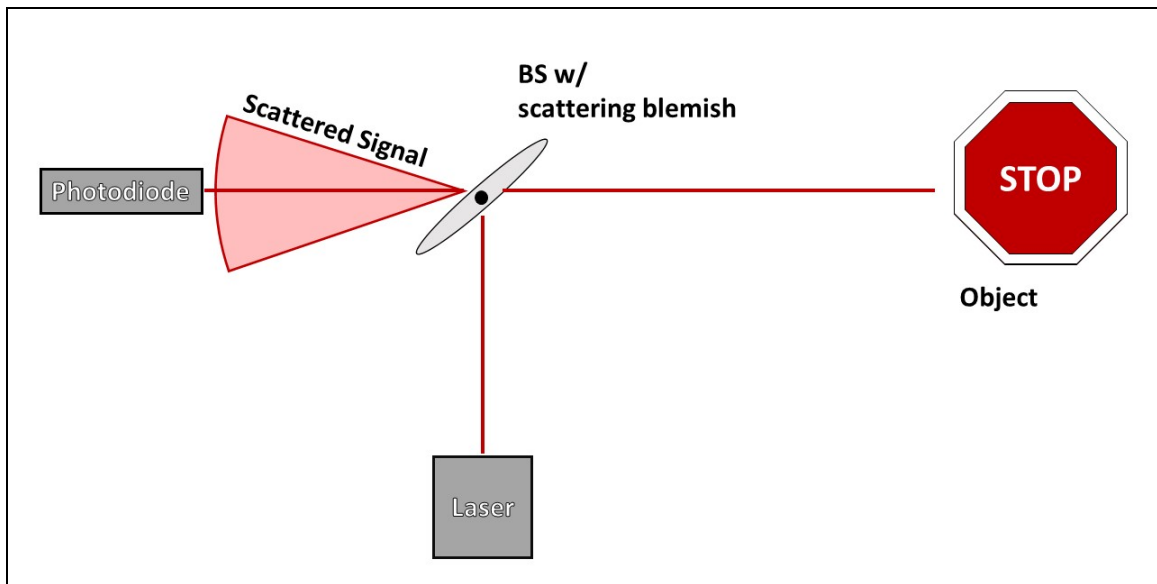
This system is useful because of its simple implementation of the optics. With two separate axes for the light to traverse, designing the system comes down to pointing the two components in the same direction and tightly packaging them together. Despite this optical simplicity, the system quickly becomes very complex with regards to electronics and computing.

The most salient issue that arises when attempting to implement such a system comes down to the ability to electronically resolve the time difference between the emission of the laser and receipt of the return signal. Disregarding pulse shape and size, high end electronics can operate at a limit of nanosecond time scales, and even that is difficult to achieve. Light leaving the laser and interacting with an object one meter in front of the system will return a signal to the detector in approximately 7 ns. That is an extremely short time for electronics, to the extent where issues may arise with pins or wires being too long, causing electrons to flow too slowly for the timing of the emitter and receiver to synchronize and accurately recreate a distance measurement. As such, designing such a system may seem simple and easy enough, but the issues inherent to timing electronics prevents accurate development and troubleshooting of the system, and as such, we have ruled out this technology from our implementation.

5.3.2 LiDAR, Optical t_0

In order to surmount the problems posed with utilizing timing electronics in the previously discussed iteration of LiDAR, our proposed solution is to generate our starting time through analogue, rather than digital means. This can be achieved by somehow feeding the initial signal from the laser into the detector before that signal travels out of the system and interacts with an object. We have determined that a clever implementation of a beam splitter with a small, hand carved blemish would suit the application well, as can be seen in the figure below.

Figure 51: LIDAR (Optical t_0) System Diagram (Permission not needed)



As can be seen in this figure, light is emitted by the laser, before interacting with the beamsplitter. The laser should be focused on the blemish, which will scatter light in every direction, including towards the photodetector. The photodetector will generate a response to this light, which we can denote as our starting time. The light from the laser simultaneously reflects off the beam splitter, travelling and interacting with an object before passing through the beam splitter and into the detector.

Such a design entirely eliminates the issues regarding sending simultaneous electronic signals in a short period of time. Rather, a signal is sent directly to the laser diode and the responses generated by the photodiode serves as the only timing mechanic in the system. However, there are two main issues with this iteration of a LiDAR system.

The first issue comes down to power. In order to keep the system eye-safe our laser must operate at a relatively low power. However, considering the reflections through collimation optics, the beam splitter, and off of the reflecting object, it is difficult to receive a respectable amount of noise on the photodiode. This issue is greater in this system as opposed to the electronically timed system due to the beam splitter dumping power through its scattering blemish and two transmission and reflection interactions.

The second issue, and likely the more constraining one, relates to the signal speed of the system. Specifically, in our previous system we consider a system measuring an object at a distance of one meter, which corresponds to a time of flight of 7 ns total, from the output laser facet to the photodetector. The most

common method of detecting incoming signals is using a rising edge technique, by which we observe the current being generated by the photodetector to increase at a certain slope or rate. The second most common technique is to find the centroid of both the initial pulse and the return pulse and comparing the time difference between the two. Both of these methods require the pulses to have a separation in time, in order to register them as separate pulses, as illustrated in the figure below.

Figure 52: Optical t_0 Signal Pulses (Permission not needed)

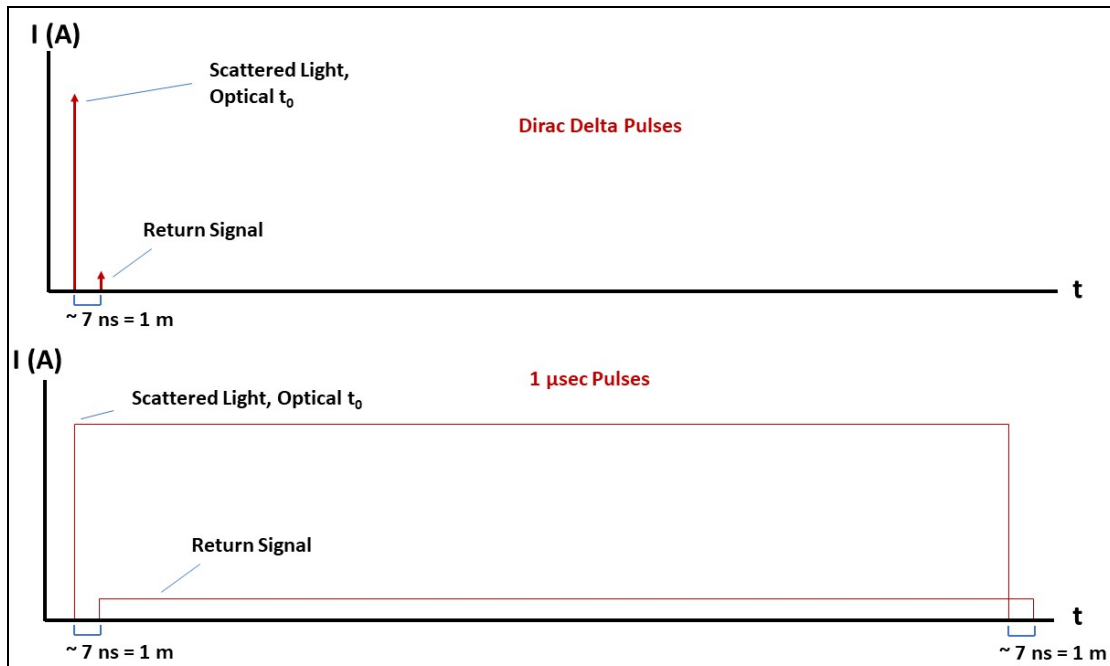
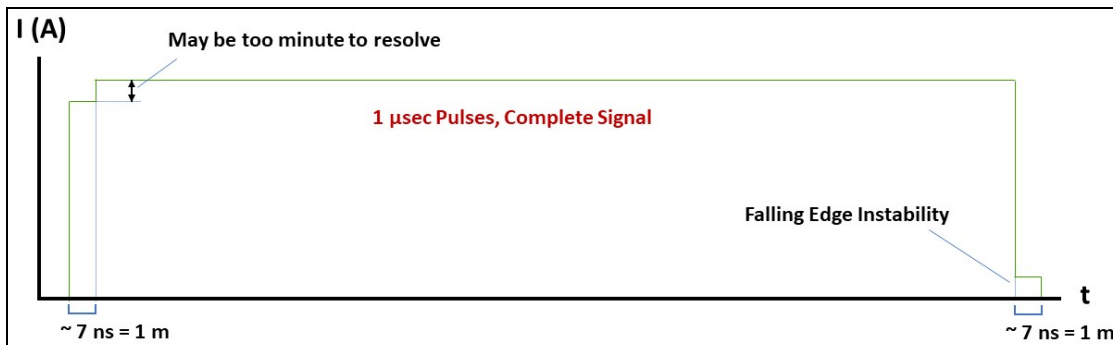


Figure 53: Optical t_0 Signal Concerns (Permission not needed)



As is shown, such a system would work perfectly for infinitely short Dirac-Delta pulses. However, such a pulse is not physically possible to generate. As such, a realistic requirement would be for us to generate pulses from our laser diode on

the order of 7 ns or less in order to approximate Dirac-Delta pulses. This would allow us to accurately resolve the time between the two signals and, as such, determine the distance of the object being ranged by the system. This switching speed is very fast and would be costly to produce and implement in our system.

Alternatively, we can attempt to use more easily generated pulse lengths, say on the order of a microsecond. There are multiple products on the market that will drive a laser diode at a microsecond pulse rate. Barring eye safety and power concerns, there is a glaring issue with using this pulses. Because they are temporally much longer than the amount of time it will take for the pulse to return to the photodetector, there will be a significant overlap where the majority of the initial timing signal and the return signal will be incident on the photodetector simultaneously. This will clearly interfere with our ability to measure the rising peak of each signal separately. There are two potential solutions to this that would allow us to implement this form of LiDAR in our device.

The first solution would be to measure the slight increase in photodiode current output. The figure above illustrates the theoretical increase in output current that occurs in the time between the initial, scattered timing pulse received by the photodetector and the return signal pulse from the object. These two should still be separated by approximately 7 ns for an object 1 meter away from our system, and as such the total current should increase, allowing us to discern the timing between the initial and returned signal. However, it is unlikely that all the components in our system, including the laser diode, photodetector, and time-to-digital converters among others, will produce output signals that rise quickly enough to provide a stable output such as that which is illustrated above. This ambiguity on the received signal would likely displace our measurements by several nanoseconds, resulting in large errors in our final product. Additionally, depending upon the material composition and distance of the object we are ranging, the return signal may be very weak and indiscernible from the relatively powerful initial timing signal in many cases. This again leads to high large errors in our final product, due to our inability to distinguish between our two signals whatsoever.

The other way we can work with relatively long pulses is to track the difference in the edge at the end of the signal. This method would theoretically allow us to distinguish between the maximum of the photodetectors output and the subsequent minor output before the signal dropped back to dark current levels. This overcomes the issue presented with using the beginning of the signal with more discrete current levels. However, it is likely that the falling edge experiences instabilities stemming from both the laser dropping off and potential dispersion and broadening occurring as the signal travels through the system and the air. Additionally, the concerns regarding rise and fall times of the photodetector are still valid in this method. As such, the broadened signal and

ambiguous speeds in our system would still lead to many inaccuracies and processes in this system.

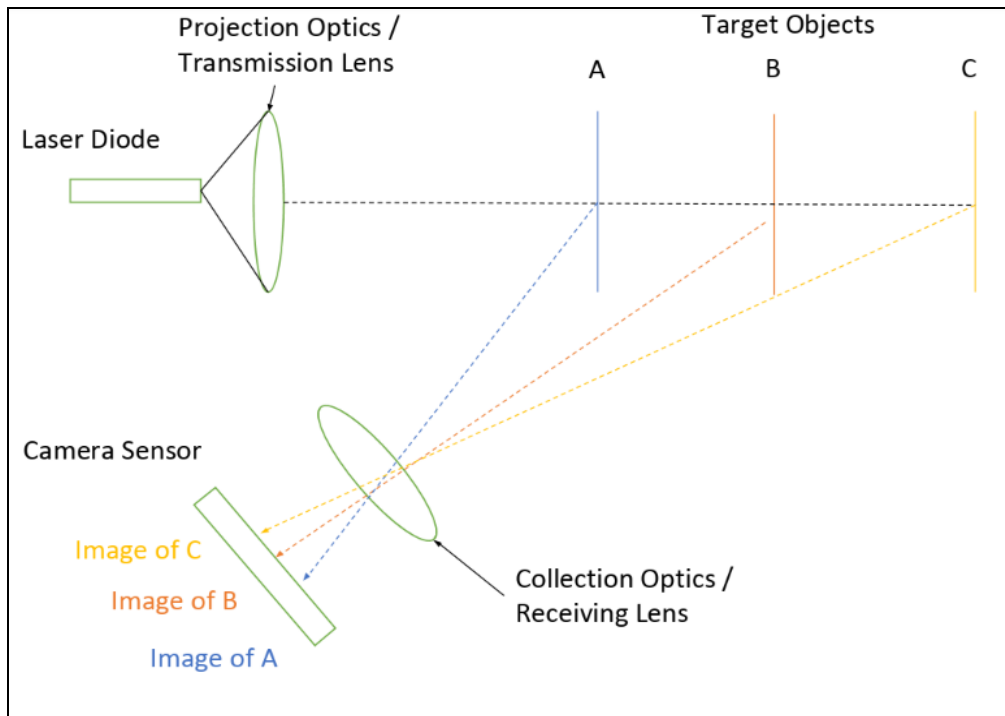
We have attempted to address both the power considerations and signal differentiation issues in this iteration of the project, but have found them to be nigh insurmountable given the scope and budget of this project, and have therefore determined that implementing a LiDAR solution is not feasible for our device.

5.3.3 Laser Triangulation

Two designs were explored for the laser triangulation system to detect objects. As mentioned in the research phase, the geometry of the laser triangulation system varies with specular reflection vs diffuse reflection due to the amount and path of the light that travels back to the CMOS detector. The points of consideration influencing the design also included whether to use a laser spot or laser line, type of target object characteristics, maximum detection range, and ultimately packaging.

The first design can be seen in the figure below:

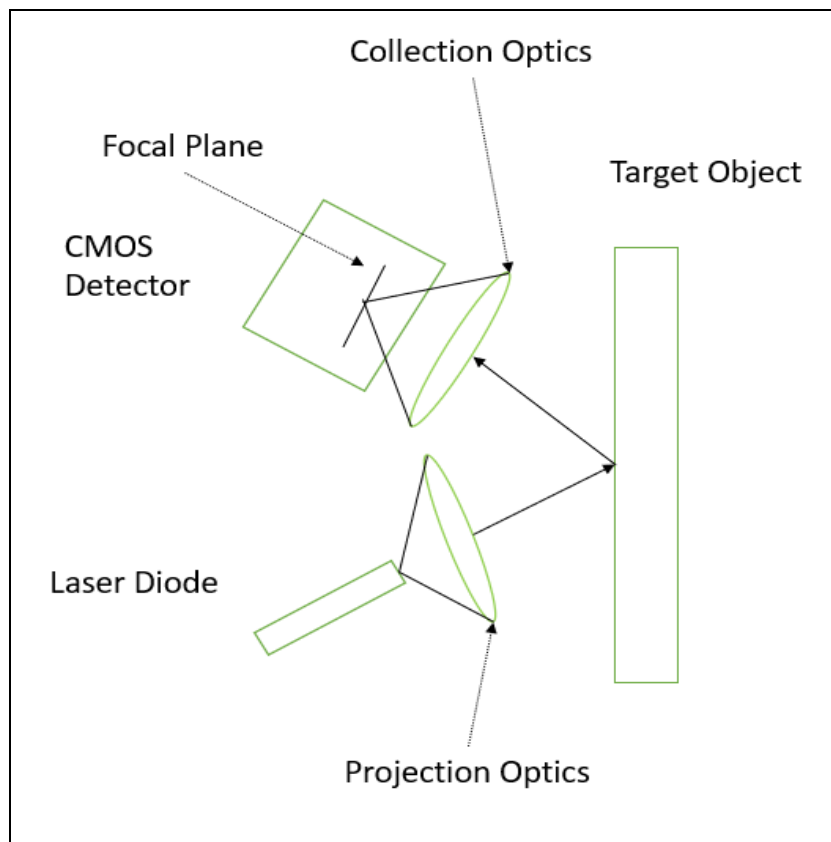
Figure 54: Specular Reflection Method (Permission not needed)



In design one, the principles of laser triangulation remain the same using a diffuse reflection model. Light travels perpendicular to the target object before light is diffusely reflected.

The second design can be seen in the figure below:

Figure 55: Regular Reflection Model (Permission not needed)



The main reason why the two designs differ is because the first model is geared toward common everyday objects a person may encounter when walking such as tree, tables, walls, etc... The second design is geared towards detecting metallic objects and highly reflective objects. After discussing with Central Florida Lighthouse the decision was made to focus more on trees, tables, walls or objects which reflect diffusively. Design 1 also allows for a larger working range of object detection as the CMOS detector has large angles to adjust and measure displacements of the laser beam.

After evaluating both of these designs, the project will moved forward with the diffuse reflection model. The majority of objects that the visually impaired people will encounter in the real world exhibit properties which trend more towards diffusely reflected objects. One of the limitations of the laser triangulation system developed will be the detection of windows and glass doors.

5.4 Receiver Signal Processing

When measuring light, the electronic components used must be fast enough to record the light beam. The traditional way of doing this is to use an integrated device that would include something like an FPGA array in combination with a microcontroller. A second option that was released more recently is a Time-To-Digital converter. Below are some considerations we made when deciding on an implementation.

5.4.1 FPGA Array

The field programmable gate array, or FPGA, is a semiconductor device which contain programmable logic blocks and interconnection circuits that can be reprogrammed on-the-fly to provide flexible functionality after manufacturing. This contrasts with microcontrollers, microprocessors, and application specific integrated circuits (ASICs), which are hardwired once the manufacturing process is complete. The main advantages of the FPGA are thus flexibility, which allows for quick bug fixing, and performance advantages for some applications due to the parallel computing and logical optimization capabilities of the FPGA structure. The major trade-offs for using FPGAs is a significantly higher power consumption and higher difficulty and time under development due to the need to code the FPGA from scratch using hardware description language (HDL). Because of the relatively high power consumption and added complexity of the FPGA, it is not the best choice for our design. {rscasny, 2018 #30}

5.4.2 Analog-To-Digital Conversion

The next option we have for converting light to a digital signal in our design is the Analog-To-Digital Converter (ADC). As its name suggests, the ADC is a system, most commonly in the form of an integrated circuit, that converts analog signals, such as light and sound, into a digital signal. For our application, the ADC will convert the optical signals collected by our receiver into a digital signal which can be used by our microprocessor. In order to relate a digital value to an analog voltage, the ADC uses a ratio established by the system voltage and the number of bits, a metric which is referred to as the resolution of the ADC.

$$\frac{ADC \text{ resolution}}{system \text{ voltage}} = \frac{ADC \text{ output}}{input \text{ voltage reading}}$$

For example, a typical value for ADC resolution and system voltage might be 1023 (representing a 10-bit resolution) and 5 V respectively. Given this ratio of

1023 to 5 V and an input voltage reading of 4 V, an ADC with output a value of 818.

Some of the important specifications we will consider when looking for an ADC are sampling rate, resolution, signal-to-noise ratio, and power consumption. We considered several devices when choosing an ADC for our design. Below are several of the options we researched.

The Texas Instruments chip ADS1675 is a high-precision ADC which can achieve sampling speeds of up to 4 mega-samples per seconds (MSPS). It is a single channel device with a resolution of 24 bits, a serial interface, and extremely low passband ripple and voltage drift characteristics, and a signal-to-noise ratio (SNR) of 107 dB. As far as power is concerned, this chip requires an analog supply of 5 V and a digital supply of 3 V, and it dissipates 575 mW of power.

Another option, also from Texas Instruments, was the ADC3244. This is a high-speed ADC with a max sampling speed of 125 MSPS. It is a dual channel device with a resolution of 14 bits, a serial low voltage differential signaling (LVDS) interface, and an SNR of 73.1 dB. This chip runs on a single supply of 1.8 V boasts an ultra-low power consumption of 116 mW per channel.

The third offering we considered from Texas Instruments was the ADS6148. Like the ADC3244, this is a high-speed ADC and can achieve an even higher max sampling speed of 250 MSPS. It is available in 12-bit or 14-bit resolution options and can be configured for either parallel CMOS or parallel LVDS interfacing. It's SNR of 72.7 dB is comparable to the ADC3244. At its highest sampling rate, this chip has a power dissipation rate of 687 mW.

Below is a table comparing several relevant specifications of the ADS1675, ADC3244, and ADS6148 devices.

Table 20: Texas Instruments ADC Component Comparison Chart

	ADS1675	ADC3244	ADS6148
Max Sample Rate (MSPS)	4	125	210
Resolution (bits)	24	14	14
Interface	Serial	Serial LVDS	Parallel CMOS Parallel LVDS

Number of Input Channels	1	2	1
SNR (dB)	107	73.1	72.7
Typical Power Consumption (mW)	575	232	628
Price (USD)	31.71	44.91	133.27

We also considered two offerings from Maxim Integrated, the MAX1121 and the MAX1446. The MAX1121 offers a conversion rate of 250 MSPS, comparable to the ADS6148 from Texas Instruments, but at a lower 8-bit resolution. What it lacks in resolution, this device makes up for with a lower SNR of 48.8 dB and a lower power dissipation rate of 477 mW at its max sampling rate.

The other option from Maxim Integrated, the MAX 1446, has a max sampling rate of 60 MSPS with a 10-bit resolution. It is optimized for lower-power, high dynamic performance applications with built-in digital error correction capabilities and an SNR of 59.5 dB. This device can run on a single supply of between 2.7 V to 3.6 V and it has a power consumption of 90 mW.

Below is a table comparing several relevant specifications of the MAX1121 and MAX1446.

Table 21: Maxim ADC Component Comparison Chart

	MAX1121	MAX1446
Max Sample Rate (MSPS)	250	60
Resolution (bits)	8	10
Interface	LVDS	microP/10
Number of Input Channels	1	1
SNR (dB)	48.8	59.5
Typical Power Consumption (mW)	477	90
Price (USD)	28.36	10.02

Of the ADC devices under consideration, we found the ADC3244 to be the best suited to our design. The ADC3244 provided the best balance between high sampling rate and resolution, good SNR, and low power consumption at the given cost point.

5.4.3 Time-To-Digital Conversion

The second option we have is a Time-To-Digital Converter (TDC). This is essentially a combination of both a Time-To-Analog Converter and an Analog-To-Digital Converter. Texas Instruments makes a packaged TDC which is

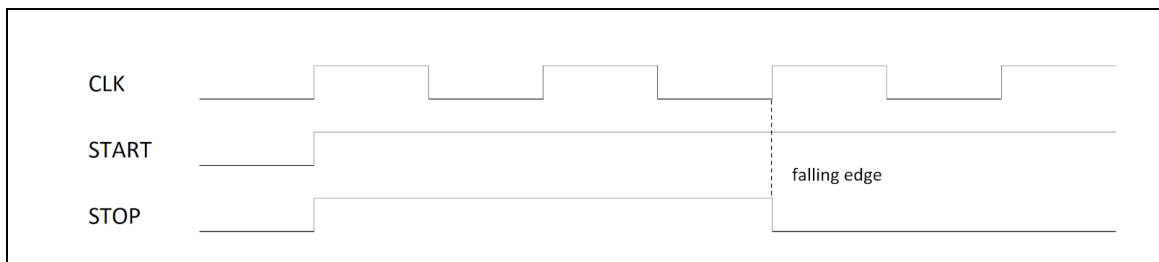
really elegant. This chip has a $\pm 55ps$ accuracy and two channels for short and long time intervals which allow for reading between 4.3cm and $>100m$.

The Time-To-Digital Converter works by measuring the time difference of a START event and a STOP event. These events are typically the rising or falling edges of an input signal. To record the time, an external clock (in our case, a

clock output from the microcontroller) is used as the frequency f_0 to calculate the period t_0 .

$$t_0 = \frac{1}{f_0}$$

Figure 56: Falling edge clock detection



5.5 Power Supply

Our design will use a rechargeable lithium ion battery as its power source in order to achieve sufficient battery life to run our system for a typical operational day, or roughly 12 hours, on a single charge. The high energy density of the lithium ion battery provides us with the power needed to run all electrical systems within a compact form factor. Furthermore, due to the low self-discharge rate of the lithium ion battery relative to other battery

technologies, we are better able to reach our goal of 12 hours of operation on a single charge. While lithium ion batteries are more costly than alternative battery technologies and require protective circuitry in order to ensure safe operation by avoiding over-charging and excessive discharge, these trade-offs are acceptable in order to harness the advantages of lithium ion battery technology.

In order to provide a constant current source to the diode, our design uses a LM317 voltage regulator. By placing a properly valued resistor at the output pin and feeding back into the adjust pin, we ensure that our current remains below the 100 mA threshold so as to protect our diode from entering into thermal runaway and burning out.

5.5.1 Battery Technology

In order to power our device we require a mobile power source which can provide up to 12 hours of power under typical operating conditions. This will allow our users to operate our product continuously throughout the course of a day and charge it at night. We considered several battery technologies when choosing a power source for our project, and compared their advantages and disadvantages to determine which would be best suited for our device.

We began by considering the battery technologies which are most commonly used in mobile devices. These include lithium ion and lithium polymer, nickel cadmium and nickel hydride, and lead acid. The main considerations as per our design constraints were weight and, by extension, energy density. Our device would require a power source which packed as much energy into as small a format as possible while not becoming cost prohibitive.

Since energy density was one of our primary concerns, lead acid proved to be a poor choice. While relatively cheap and capable of providing high levels of current, they do not pack the energy density needed for our device. Comparing the specific energy of lead acid batteries, 30-50 Watt-hours per kilogram, to that of lithium ion batteries, 110-160 Watt-hours per kilogram, shows that the trade-off between density and cost is simply not worth it in the case of lead acid batteries. It should also be noted that lead toxicity is a concern when it comes to environmental and health concerns, but this is of more importance when considering manufacture and disposal than user interaction.

Moving on to lithium ion and lithium polymer batteries, we see that the two technologies are very similar. Lithium polymer technology will provide a slightly slimmer and simpler packaging. The trade-off, however, is increased cost and a slightly less competitive energy density of 100-130 Watt-hours per kilogram compared to lithium ion. Several other advantages of lithium ion that bear mentioning are that they do not require priming when first used nor do they suffer from significant self-discharge. While lithium ion batteries do age even

while not in use, this will not be a serious concern for our project since the battery will not go for extended periods without use under normal operating assumptions. Finally, although lithium ion batteries have very low overcharge tolerance and must be monitored to ensure they remain within safe operating conditions, the circuitry to achieve this is well-studied and not difficult to implement.

Finally, nickel cadmium and nickel hydride both have lower specific energies than lithium ion, coming in at 40-80 and 60-120 Watt-hours per kilogram, respectively. Nickel cadmium has the advantage of being rugged and extremely economical, which the best ratio of charge cycles to cost of all the batteries we considered. However, it's relatively low energy density makes it too cumbersome for our application. Meanwhile, nickel hydride boasts better energy density characteristics but lacks the ruggedness and cost effectiveness of nickel cadmium. In fact, nickel hydride is the most high-maintenance of the battery technologies under consideration, requiring regular full discharge so as to prevent the formation of crystals, as well as needing very particular charge and discharge cycles to prevent performance deterioration. Even under ideal conditions, nickel hydride batteries tend to wear out too quickly and their special requirements simply impose too many design constraints for a battery technology which is barely competitive with lithium ion in terms of energy density.

Thus, the best choice of power source for our design is the lithium ion battery. Its high energy density provides sufficient power for the operation of our diode, microcontroller, and other electronics within a compact form factor, allowing our device to meet our 12 hour maximum runtime target without being too cumbersome to the user. The lithium ion battery has the additional advantage of a low self-discharge rate relative to other battery chemistries, as well as not requiring any priming or maintenance in order to function properly. While lithium ion batteries have a greater cost per cycle than alternative battery technologies such as nickel cadmium or alkaline, the cost difference is not prohibitive and the energy density advantage is too good to pass up.

5.5.2 Lithium Ion Battery Safety

All energy storage devices, including battery technologies, carry a risk, and lithium ion batteries are no exception. In order to make batteries as safe as possible, battery manufacturers are obligated to meet certain safety requirements when making their products. Likewise, designs which incorporate batteries must also include the proper and necessary safeguards to minimize the risks inherent in utilizing any energy storage device.

Lithium ion batteries designed with conventional metal oxides are approaching the theoretical limits when it comes to improving their specific energy. This has

led battery makers to focus on improving their manufacturing methods in order to improve safety and lengthen overall battery life cycle, rather than attempting to achieve diminishing returns in storage capacity. The greatest issue as regards battery safety comes from the uncommon but critical instances in which an electrical short develops within the cell. In this situation, it is often the case that the protective circuitry on the outside of the battery are not capable of curtailing a thermal runaway event once it is in progress.

It is useful at this point to consider the two basic types of battery failures. The first form occurs at predictable intervals and is linked to a design flaw involving the electrode, separator, electrolyte or processes. The second and more difficult form occurs due to unpredictable events that cannot be simplified to a design flaw. Examples of such chance occurrences include a stress event, like vibration, charging at sub-freezing temperature, or extremely unlikely incidents which are difficult to predict and thus hard to defend against. All of this being said, it is still the case that quality lithium-ion batteries are safe if used as intended, and this is especially true in designs which include battery protection circuits.

5.5.3 Battery Protection Circuits

When considering safe battery operation, the simplest safety precaution is a fuse which is triggered to open by high current. Fuses may either open permanently and render the battery useless or, ideally, open temporarily and allow for a reset and continued use of the battery. One such device which can be reset is the positive thermal coefficient, or PTC, thermistor. This thermistor creates high resistance, essentially turning OFF, when exposed to excess current but goes back to the low resistance, or ON position, once normal current conditions return.

Solid-state switches provide an additional layer of protecting by measuring current and voltage and disconnecting the circuit if the values are too high. The protection circuits of lithium ion batteries work on this on/off basis. Lithium ion battery packs also require a mandatory protection circuit as per IEC 62133 to assure safety under most circumstances. Protection measures for lithium ion batteries under this standard include any of the following:

- Built-in positive temperature coefficient (PTC) thermistor protects against current surges. [<http://www.resistorguide.com/ptc-thermistor/>]
- Circuit interrupt device (CID) opens the circuit at a cell pressure of 1,000kPa or 145psi.
- Safety vent releases gases on excessive pressure buildup at 3,000kPa or 450psi.
- Separator inhibits ion-flow by melting process when exceeding a certain temperature threshold.

The PTC and CID protections work well in small cell packs with either serial or parallel configurations, making them good candidates for our design. There also exist off-the-shelf chips that can accommodate larger cell packs, but these may not be necessary for our design. However, there are also integrated circuits for single-cell lithium ion battery, which merit consideration.

While the protection circuits we have considered thus far do help to shield the cell from external conditions, like an electrical short or defective charger, internal defects can also damage the cell. Examples of such defects include contamination of microscopic metal particles, against which external protection circuits are ineffective. It is for this reason that there is ongoing research into reinforced and self-healing separators for cells, but these innovations drastically increase battery size and cost. As such, they are prohibitive for our design and the low likelihood of such internal defects occurring in our product means that it is not a serious concern.

5.6 PCB Design

Per design requirement specifications, we shall design a custom Printed Circuit Board, have it manufactured by a third party, and assemble the necessary components onto it to provide our device with all of the functionality required, per the requirements stated elsewhere in this document. Designed with an appropriate software program, the Printed Circuit Board shall provide a platform to electrically network together all of the below components.

Under financial restrictions, the Printed Circuit Board shall be manufactured with the following requirements:

- 2 Layers
- FR-4 Material
- Lead-Free HAL plating
- IPC Class 2 Certified
- 5 Mil tracing
- 5 Mil spacing
- 0.01"+ Hole size

The third party manufacturer that we have come into contact with has graciously agreed to print our Printed Circuit Board free of charge with the above printing properties.

5.7 Haptic Feedback Devices

Haptic feedback differs from simple vibration in that it is patterned and provides more subtle cues to users. Simple vibrational feedback is largely a binary affair, either vibrating forcefully to alert users of an event or not vibrating at all. In contrast, haptic feedback can provide nuanced feedback by varying in intensity and frequency. The two major components of a haptic feedback system are the haptic actuators, which produce the vibrational effects, and the haptic driver, which controls the actuators. We will consider the performance characteristics of two haptic drivers from Texas Instruments as well as the two broad classes of haptic actuators, the eccentric rotating mass (ERM) actuator and the linear resonant actuator (LRA).

5.7.1 Haptic Driver

The DRV2605 and the DRV2603 from Texas Instrument both provide the functionality needed for our device at the low price of \$2.33 and \$1.42 per unit, respectively. Since cost was not a major differentiator in this case, we decided to use the DRV2605 on account of its faster start-up time of 0.7 ms, which makes it almost twice as fast as the DRV2603 with its 1.3 ms start time. Both devices can perform automatic resonance tracking, which improves LRA efficiency significantly. However, the DRV2605 also features a smart-loop, which provides automatic over-drive and braking, and automatic diagnostic and calibration features. This makes the DRV2605 the more attractive design option.

5.7.2 Haptic Actuator

The major considerations for a haptic actuator are its response time, vibration strength, and power consumption. The ERM actuator is driven by DC voltage while the LRA is driven by AC voltage. The ERM operates much like a regular DC motor, using the magnetic field of a direct electrical current to move an object in a circle. Unlike regular DC motors, however, the ERM moves a small weighted object, the so-called rotating mass, that is off-center, or eccentric, from the point of rotation. This rotating mass produces an uneven centripetal force, causing the entire motor to move back and forth and to produce a lateral, or side-to-side, vibration.

In contrast to the ERM, the LRA use a voice coil that takes an AC input and produces a corresponding vibration with a frequency and amplitude corresponding to the incoming electrical signal. Since the device must be controlled with alternating current, the necessary circuit to drive the actuator is significantly more complex than a circuit used to drive an ERM motor with direct current. In spite of the increased complexity, the devices have several unique advantages. LRA's will typically consume less power to produce a vibration than

an ERM motor, and their performance characteristics allow for significantly shorter start-stop times in typical applications. In addition, LRA's don't produce as much noise because they do not have a spinning mass inside of them.

A further point in favor of the LRA is that their typical start time is between 5 and 10 ms, a fraction of the time required to produce a vibration with an ERM motor. This incredible speed results from the immediate movement of the magnetic mass as current is applied to the voice coil inside of the device. In an ERM actuator, the vibration can only be produced after the motor reaches its operating speed. Thus, even when overdriving the motor to produce faster acceleration, the ERM can require between 20 and 50 ms before reaching a desired intensity of vibration. Unfortunately, the stop time of an LRA can be significantly longer than an ERM motor. The trade-off is that the LRA can take up to 300 ms to stop vibrating due to the continued storage of kinetic energy in the internal spring during operation. Thankfully, an active braking mechanism can also be used for an LRA. By performing an 180-degree phase shift of the AC signal provided to the actuator, the vibration can be stopped within approximately 10 ms by producing a force opposite to the oscillation of the spring.

Thus, both LRA and ERM actuators are capable of operating within desirable response, power, and vibrational ranges. This is especially true when they are driven by the DRV2605 haptic driver from Texas Instruments, which allows us to optimize actuator performance using a proprietary software library. In making our final decision, we opted to use Adafruit ERM actuators for our design, as they provide excellent performance characteristics at an affordable price point and use a simple DC power input.

6. Projected Software Details

The software that is run on the MCU has the responsibility of taking in the input signals (i.e. Laser ToF, controller input, voice input) and generating output signals (i.e. haptic feedback, audio commands). Due to the nature of this project, the software must also be able to handle the laser system with relatively little delay between receiving the input and providing feedback to the user to signify how close/far an object is.

At the startup of the program, the necessary libraries should be loaded into memory for use by the program. Following the setup stage, the software should be ready to provide functionality based on the settings of the user:

Table 22: Variable-Mode Software Functionality

	Configuration/Input:	Software Behavior:
1	Device Off	No power delivered to components.
2	On + Continuous Survey Selected	Loop detection every half (1/2) second, get distance information and report to user.
3	On + Intermittent Survey Selected	Loop detection every half (2) seconds, get distance information and report to user.
4	On + Manual Survey Selected	Activate detection only when prompted by user (i.e. button press) Low-Power Mode when not in use

After the software reads the settings, it should continue to be aware of any changes to these settings and change accordingly. The flow will then continue on to enact those functions.

6.1 Development

To develop the software, our Computer Engineer, Hunter, has designed a plan (modeled after the *V-Model* design) for the development lifecycle as outlined below:

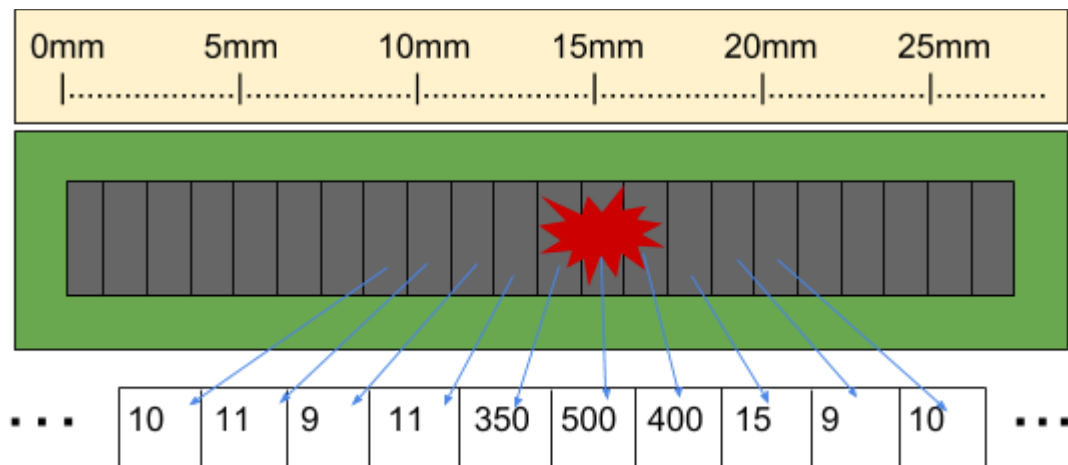
Table 23: Software Design Plan (V-model)

Step	Action	Description
1	Plan	Decide what functionality is needed by the software.
2	Implement Elements	Code up individual functions and test them individually.
3	Validate	Test code to work altogether.
4	Calibrate	Modify code variables to produce desired responses.
5	Reiterate	Repeat steps 3 and 4 as needed.

6.2 Survey

When the device is set to survey, the software activates a laser pulse, the return beam is read off of the image sensor array and a software array stores the resulting voltages recorded. The software will then find the array index which recorded the highest voltage. This index will correspond to a distance on the image sensor array and allow us to triangulate the distance to the object.

Figure 58: Linear Image Sensor Array Value Storage and Measurement (No permission needed)



Returned to the user, based on this information, is an activation of the haptic motor for a predetermined amount of time with an intensity value that is

inversely proportional to the distance recorded. Additionally, the software may execute an audio file to produce a pre-recorded instruction (e.g. “One meter.”, “Six feet.”).

6.3 GPS

One of our stretch goals is to include the functionality of navigating users to particular locations. On our college campus, one of the main issues we were made aware of was the difficulty of navigating the large university in order to find one of the many buildings. To aid individuals in navigating to these preset locations, the software shall keep a database of the saved locations and be able to navigate a user to them when selected. To set a location, the user shall verbally give the name of the location and the software will save the audio cue along with a string that indicates that destination’s GPS coordinates. To pick a destination, the software shall play back audio cues ordered by their coordinates distance from the user (closest location first). When the user hears the location that he wishes to set as his destination, the navigation process will begin. The location of the user will then be determined relative to the desired destination using the Euclidean Distance formula:

$$E = \sqrt{(\Delta x)^2 + (\Delta y)^2}$$

This formula (where Δx is the change in lateral coordinates and Δy is the change in longitudinal coordinates) will allow the software to give feedback to the user to indicate what general direction he/she will need to travel in to navigate to a location. To give updated instructions, the software will determine the user’s current direction by reading a compass sensor mounted onto the PCB.

6.3.1 Compass

In addition to the GPS module, we seek to stretch our capabilities of navigation by integrating a compass module. This module will help us be able to calculate the direction that the individual needs to travel in, we need a way to determine what direction the individual is currently facing. The compass chip would tell the microcontroller how the chip is oriented to the earth’s polarity. By strategically positioning the chip on the wearer, we can determine where the user is facing and use that data to inform him/her what direction to travel in.

The Honeywell HMC5843 is an integrated circuit designed around a magnetoresistive sensor. The magnetoresistive sensor is capable of detecting a difference in magnetic fields. Very thin strips of nickel-iron are aligned in the sensor such that the change in voltage caused by the presence of the magnetic field are measured. In the HMC5843, three strips are placed in orthogonal directions to provide a three-axis measurement

6.4 Interrupts vs. Polling

Obviously, we can't fire all of our peripherals and components to run all the time. That would burn through our battery power in no time. Imagine the laser always on, the detector always detecting, the conversion chips always converting signals, the haptic feedback motor always vibrating, etc. No, instead we need a more elegant solution to fire up our components only when we need them to run.

The alternative ideology is rather simple: instead of firing everything all the time, we would rather leave everything off most of the time and only turn specific components on when we need them. But how shall we implement this new idea?

There are two common solutions: *polling* and *interrupts*. These are both well documented and both used in industry for a variety of situations for different reasons. Though, arguably, the use of interrupts is far more common than polling.

First, polling is an easy way to implement infrequent activation of elements. Polling works, depending on the implementation, by the central processing unit "testing" or "asking" each component to see if the processor is needed to do anything yet. To implement this, each device has a flag bit that indicates if it needs the processor (`flag_bit = 1`) or not (`flag_bit = 0`).

The benefits of polling are that polling is consistent and happens every loop iteration, the poll does not need any additional resources to implement, and it is easy to code exactly when a poll will take place.

The negatives to polling are that polling only takes place once in a cycle which could take a long time depending on how big our loop is, the poll could never be reached due to misdirections of code around it, and, lastly, it takes up clock cycles and, therefore, power and time just to be told nothing will happen the majority of the time.

While consistent, polling is resource hungry. To solve this, the interrupt method was invented. Interrupts are implemented at a hardware level on the processor unit. There is an interrupt handler that receives flags from peripherals to say that

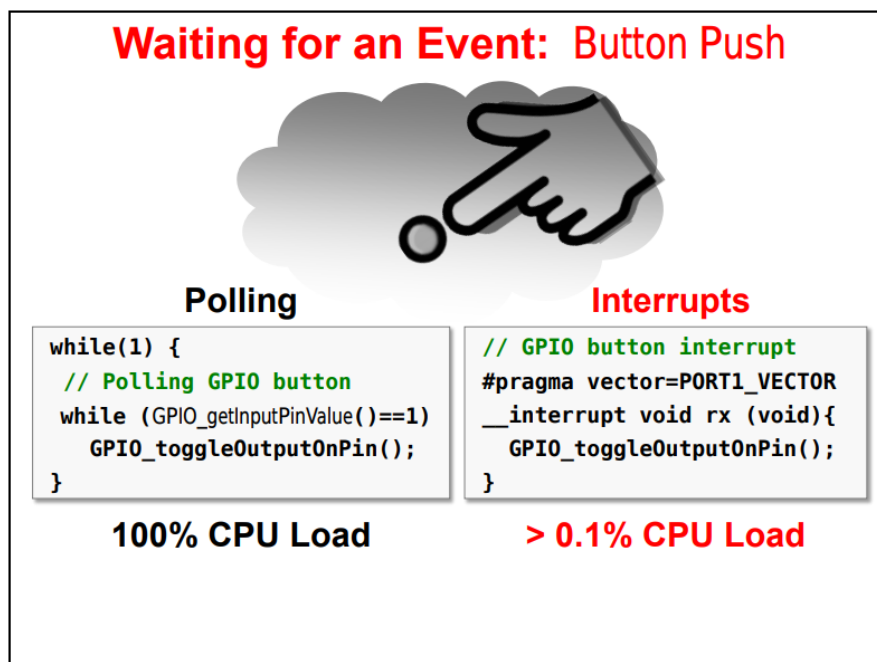
they need processor time. As the software is running, the CPU notices that a flag is set in the interrupt handler and it goes and takes care of it.

The benefits to interrupts are that peripherals are able to indicate nearly immediately their needs to the processor and by not checking each of the peripherals every loop iteration, power and time are saved.

Negatively, however, interrupts can disrupt the behavior of the rest of the peripherals (especially if some interrupts are more important than others), and it is not as clear when the interrupts will occur in the code (to account for this, we can turn on and off the interrupts at certain times).

Below is an example of what both methods would do in the event of a button being pushed. For this project, we will be using an interrupt handler protocol.

Figure 59: Polling vs. Interrupts



6.5 Low-Power Modes

Not only will using interrupts help us save power, but so will taking advantage of the MSP430's Ultra Low Power modes. When going into one of the pre-configured states, the microcontroller shuts down some of its hardware features. In addition to the fully active mode, TI offers the five modes listed below:

Table 24: MSP430 Ultra Low Power Modes

MODE	SCG1	SCG0	OSCOFF	CPUOFF
LPM0	0	0	0	1
LPM1	0	1	0	1
LPM2	1	0	0	1
LPM3	1	1	0	1
LPM4	1	1	1	1

For our purposes, this means we can predominately keep the microcontroller off when the device is not in use, but wake it up when necessary to perform its functions before going back to sleep. Depending on what clocks we need for our peripherals to run, we can keep the device in Low Power Mode for most of the time. This will save us *a lot* of power.

6.6 Programming Language

We have the ability to write code in both C and Assembly with any of these microcontrollers. These languages are both necessary in certain conditions for their respective traits.

Predominantly, C is the preferred programming language. That is because C a high-level programming language. It is much easier to use and understand quickly than Assembly. Code written in C is shorter too. For example, some code written in C could take half or a quarter of the number of lines the same program written in Assembly would take. {Kent, 2011 #31}

Another benefit of C is the portability. Thinking beyond the current design, if we were to port our code to an upgraded microcontroller or a better architecture in the future, the assembly code would need far more time to be refactored (edited) than a C program.

One downside, however, is the sacrifice of speed for the ease of use. The C compiler converts all of the jumps and assignments automatically into code the processor can use before it can run. On the other hand, Assembly requires the user to make the explicit jump statements and register moves which the CPU is then able to run directly.

For the ease of writing in C, we are willing to sacrifice some compile time to use the higher-level language. If necessary, we may use an inline assembler which

will let us indicate that we are writing a piece of code written in Assembly Language to be read as such. The speed of Assembly can then be utilized amidst the ease of writing in C. This will allow us to have the best of both worlds.

7. Projected Testing and Prototype Construction

The testing of individual components will be done to confirm that our individual components meet the standards on the data sheets provided by the companies. This stage is critical to prevent the usage of the components incorrectly which can lead to damages later when after the system integration a performance tests conducted. Without this procedure, we would not be able to tweak our design as necessary and meet our engineering requirements. It is known that the ideal state can never be reached which is why multiple iterations exist of the same product.

7.1 Prototyping

The project prototype construction consists of the opto-mechanical design of the housing, PCB, and coding strategy. The initial prototype was done on an optical breadboard to verify that the laser triangulation principle was viable. A red laser pointer was initially used for alignment of the optical imaging system before transitioning to the near infrared laser diode from Thorlabs. Special mounts for the the cylindrical lenses were 3D printed to aid in the collimation process.

7.1.1 CNC Machining vs 3D Printing

An integral part of the project involved whether or not the final product would be held in place using custom machined parts or 3D printed. CNC machining is often defined as a subtractive process. More often than not, you begin with a block of material typically metal and using special cutters are able to shape what you desire. CNC machining is great because often you are able to achieve tighter tolerances than if you chose to 3D print. {Varotsis, 2018 #32} 3D printing on the other hand is an additive process. Material is added on in layers until the final part is complete. The typical material used for 3D printing is plastic. The decision to grow the housing was selected due to the factors of complex shape form, number of iterations required, fast turnaround time, material, and low cost. Machining housing to hold optics in place is difficult due to the surface properties and topology of a majority of optical lenses. In addition, to hold Optics in place would often require the application of an adhesive on the surface. If the adhesive was to get on the lens surface then this could negatively impact the imaging system performance. The centering of optics onto a housing would also require shims or pins and in the process this would lead to edge chips on our sensitive Optics. Furthermore, if the surface is not cleaned and primed accurately then the Optics could have a poor bond strength and not adhere. This could lead to Optics falling out and leading to damage. Machining

metal to house the prototype would also make it very heavy and work against the project marketing requirements. 3D printing is powerful because it enables for rapid development with computer aided design using CREO Parametric 2.0. A custom fit of the lenses can be assembled to ensure the Optics will fit in the right locations and be spaced accurately. In addition, if there is a tight interference fit on any of the parts in the housing then we are able to sand that down to create a better fit for the components. Plastic weighs significantly less than metal and was the main driving factor behind this decision to choose 3D printing over CNC machining. The ability to upload a design and get a prototype housing in 24 hours made us select 3D printing over CNC machining.

7.1.2 Optical Housing

The opto-mechanical housing of the laser diode, optical lenses, and CMOS camera are critical to the stability of the system so that once it is calibrated it remains calibrated. The opto-mechanical housing was modeled in CREO parametric software. Different views of the first iteration of the optical housing can be seen in the first and second figures below. The first figure shows how all the electronic components and optics will sit within the housing. The lenses will be inserted into place and sandwiched in the same way a two part box is closed. Additional refinement of the model and further iterations will be needed to carve out space for any wires which need to be connected within the housing. The second figure shows the a right side view of the optical housing. This part is essential to be designed correctly in order to ensure that the maximum amount of light is transmitted to the target object as well as the amount of light is collected back on the CMOS detector. If the size of the opening on the CMOS side is not big enough then we will not be able to collect as many photons. If the size of the opening is too large then we pose the risk of loose optics and exposing the optics to potential damage. The size of the openings of the model were designed with the clear aperture in mind. The clear aperture is defined as the limited light-gathering area of an optical system. What typically limits the clear aperture is the edge or outer surface of the lens we have chosen. {, 2018 #33}

The clear aperture data on the lenses used in the sizing of the openings was the full diameter of the lenses selected. The depth and shape of the openings were manipulated/carved out by considering the radius of curvature of the lenses as well as the thicknesses.

Furthermore, the material used to print the housing of the laser triangulation system was a plastic called ABS. This material was selected due to the fine resolution details able to be 3D-printed as well as the strong thermal coefficient. This in turn makes the opto-mechanical housing very robust. A first iteration of the computer aided design of the mechanical housing for the laser triangulation system can be seen in the figures below. The mechanical housing which secures

the optics in place will be sure to be open enough for the clear aperture of the Optics. This in turn ensures that the maximum amount of light will be transmitted and collected. The optical housing will be secured and closed in placed by threaded inserts placed outside of the box.

Figure 60: Front Side View of Optical Housing (Permission not needed)

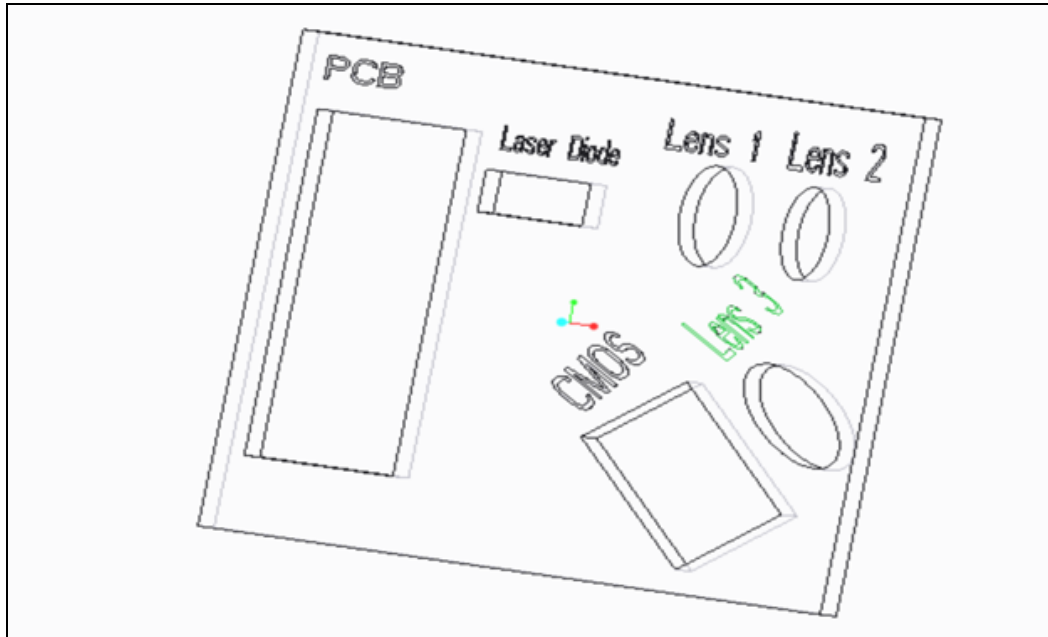
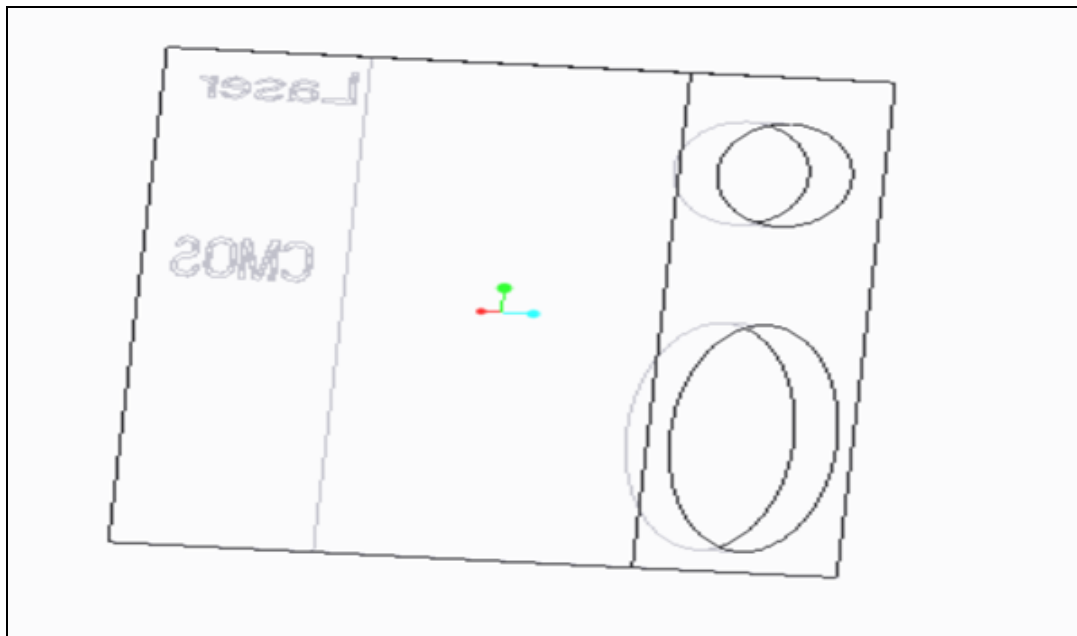


Figure 61: Right Side View of Optical Housing (Permission not needed)



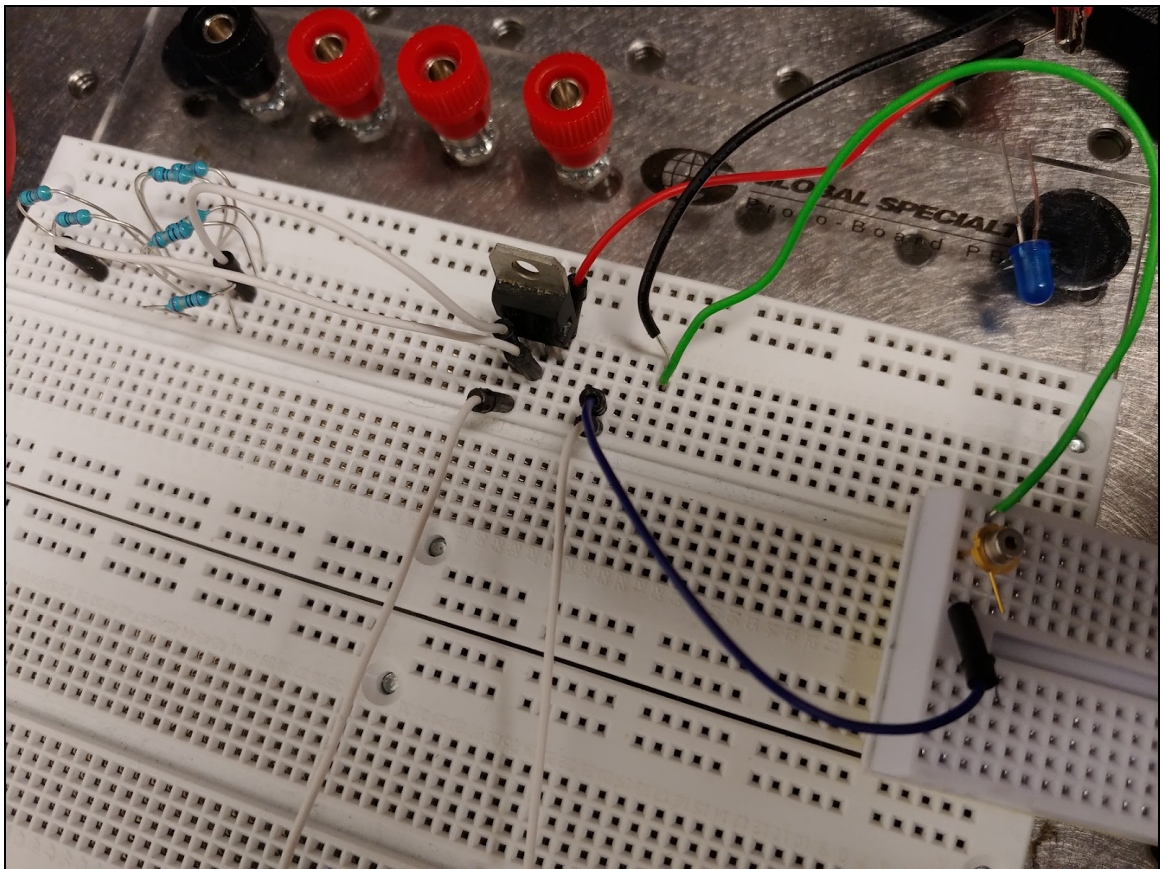
7.2. Hardware Specific Testing

The hardware specific testing for this section included breadboarding the constant current source for the THorlabs L904P010 905 nm near infrared laser diode, collimating laser diode, and imaging the laser spot onto a camera. The testing of these components are critical to ensure the timeline for the project is adhered to meet the project goals and deadlines. The collimation of the laser diode and imaging of the laser spot onto the camera off a target object ensures that the laser triangulation principle is feasible for the project.

7.2.1 Laser Transmitter Characterization

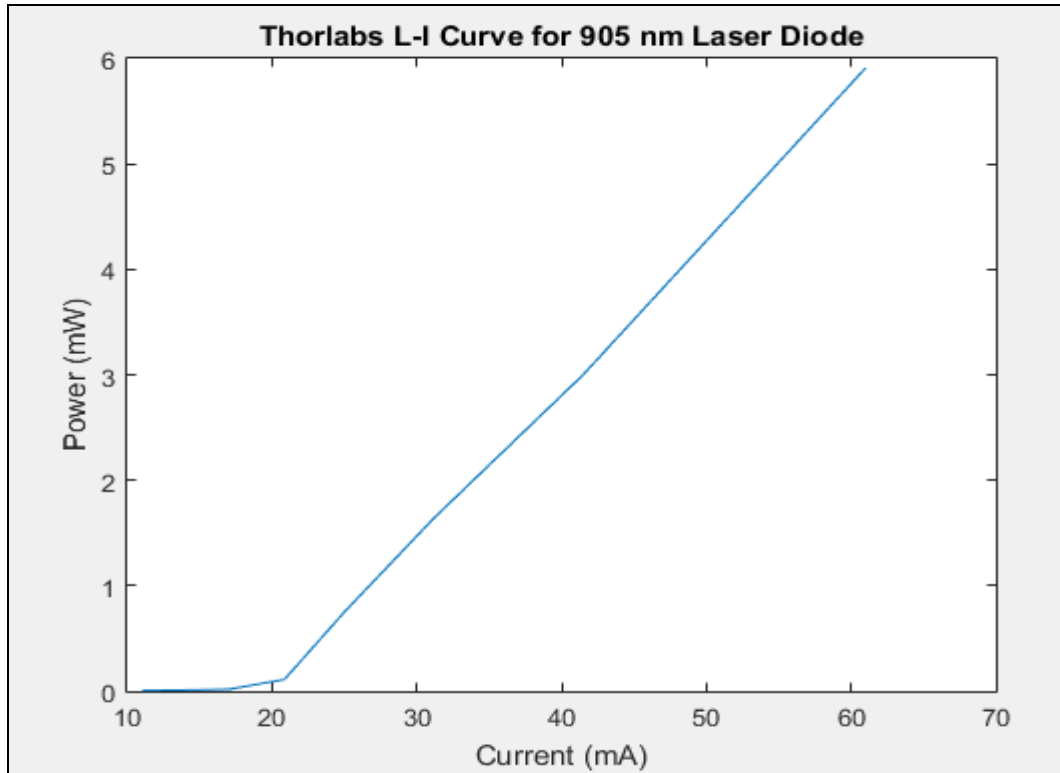
The Thorlabs L904P010 905 nm near infrared laser diode was characterized by the current- power relationship, beam-waist, divergence, spot size, and optical spectrum.

Figure 62: Breadboard Testing of Laser Diode Driver



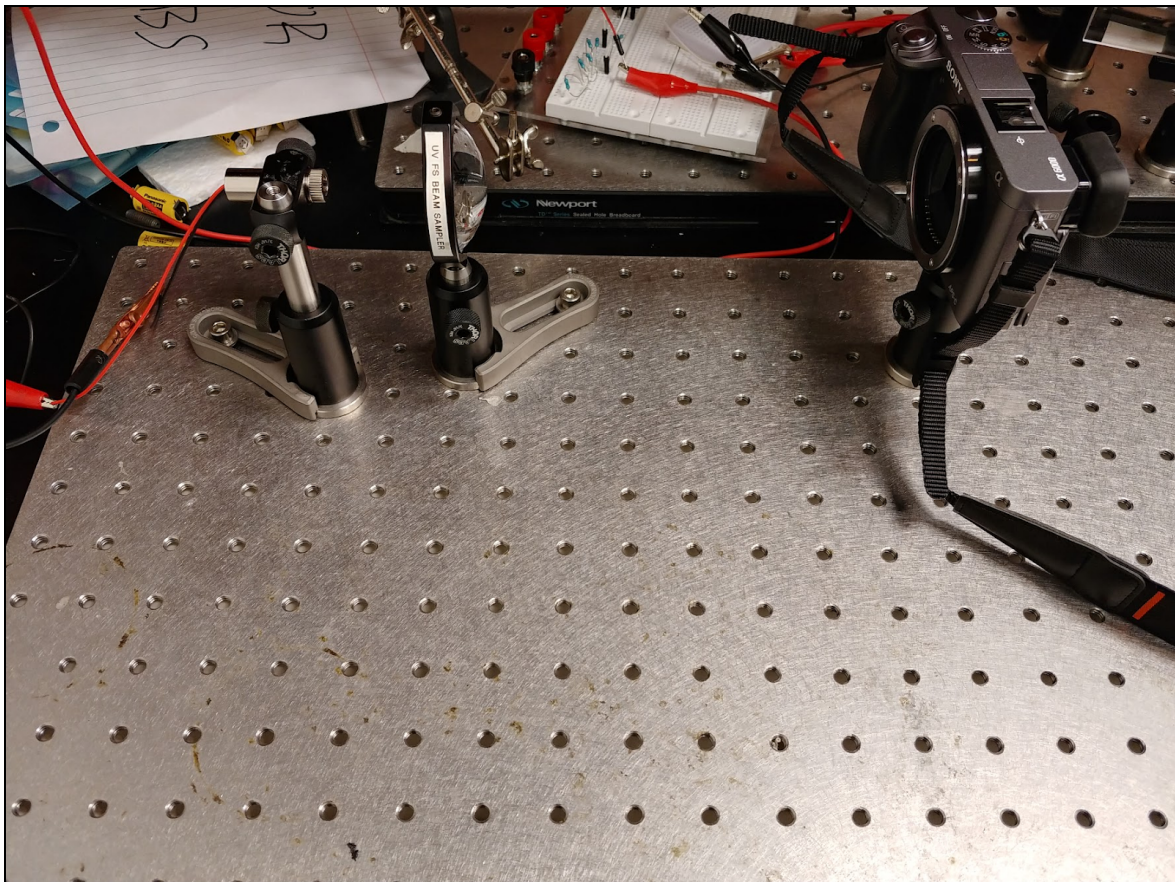
The laser diode driver circuit was constructed using reference designs provided by Texas Instruments for the LM317 voltage regulator. Establishing a resistance across the output and adjust pins creates a constant current which can then be used to power the laser diode. By adjusting the impedance between these two ports, the current can be directly manipulated.

Figure 63: Current-Output Power for Thorlabs L904P010 905 nm Near Infrared Laser Diode (No Permission Needed)



The above LI curve was created by replacing resistors in the LM317 circuit. From this we confirm that the laser diode can be turned on and operated using this circuit as well as determine the lasing threshold of the device to be approximately 20 mA. This graph also shows the “S curve” common to lasers in at the center of the operation current, which would be more easily scrutinized using a higher resolution method of capturing current and intensity information.

Figure 64: Optical Alignment for Collimation using Single Spherical Lens



The above figure shows a rudimentary collimation technique in which we use a lens with focal length $f = 7.5$ to collect as much light from our laser diode as possible and collimate it. Because of the axially mismatched divergence angles, this system is flawed and does not provide a small or fully collimated beam spot. This collimated beam spot was collected onto a camera placed approximately 20 cm away from the collimating optic, as shown in the figure on the following page.

As can be seen in this figure, the beam shape is oblong and exhibits a low energy density over the area of the spot, due to the low powered nature of our laser. We can conclude from this exercise that using a single spherical lens for our collimation is an ineffective practice that will impede our ability to image our spot and determine range information from it.

Figure 65: Spot Size using Spherical Lens and Thorlabs L904P010 905 nm Near Infrared Laser Diode (No Permission Needed)

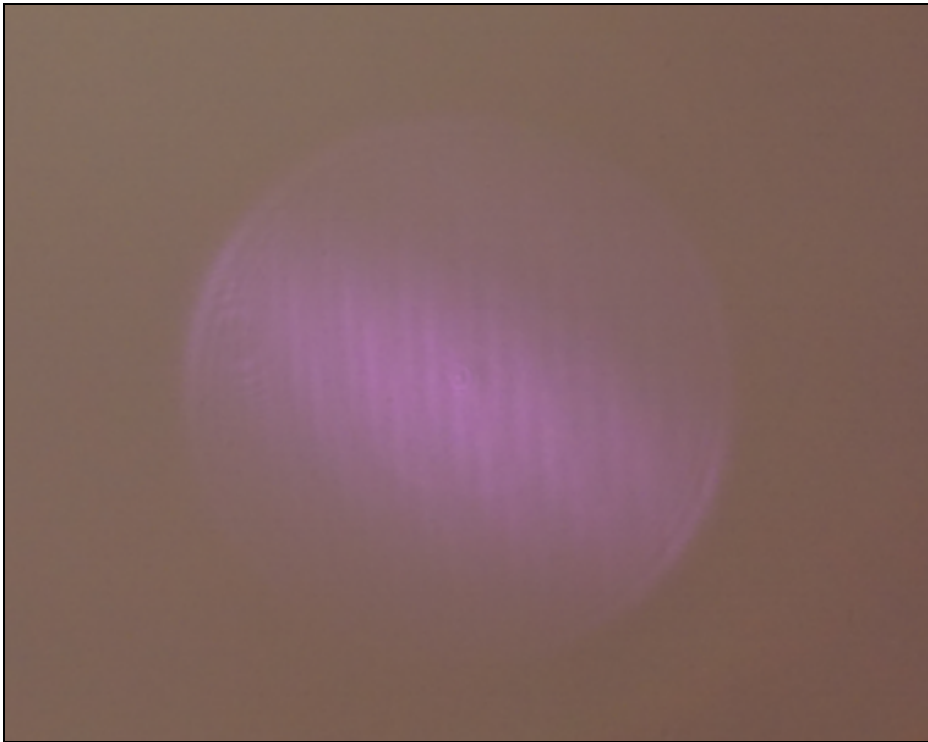
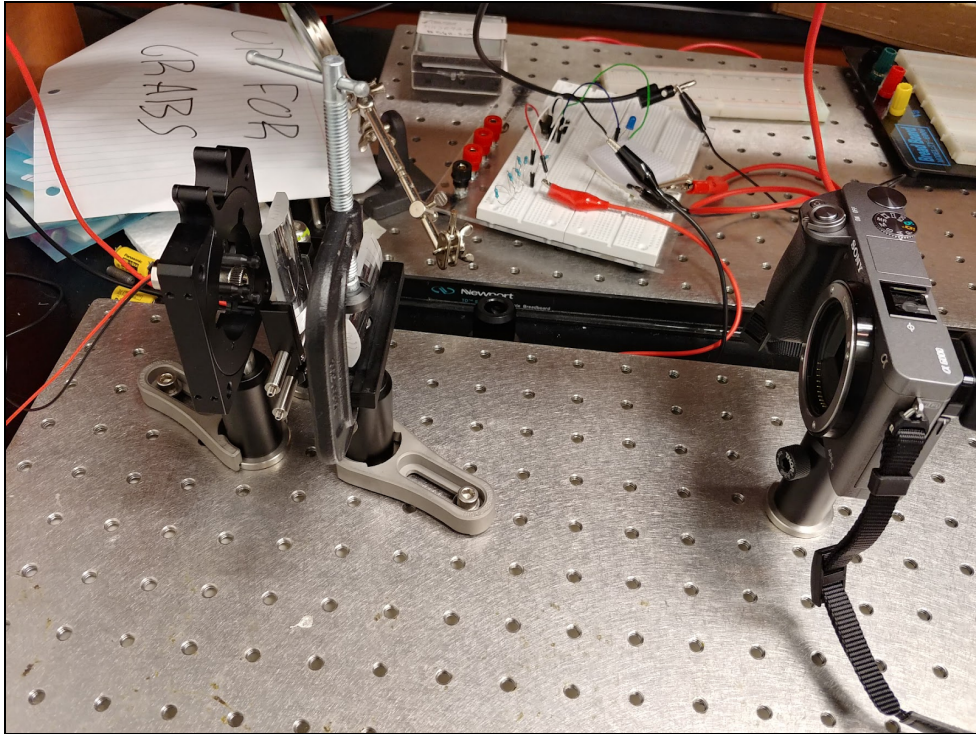


Figure 66: Optical Alignment for Collimation using Two Plano-Convex Cylindrical Lenses (No Permission Needed)



The above figure showcases our preferred method of collimation. Using two appropriately matched cylindrical lenses to individually collimate the two axes of the beam provides many benefits. First, it allows us to match the size of the beam in both dimensions, leading to a higher energy density which results in a spot that is far easier to image onto a detector at far distances, as seen in the figure on the following page.

Additionally, the use of cylindrical lenses allows us to drastically reduce our working distance by accounting for the highly diverging axis first. Using high-powered lenses reduces the focal length of the lens, allowing them to be placed closer to our laser diode. Additionally, the reduced thickness and width of cylindrical lenses reduces the space required to implement them. This allows us to more easily package them while simultaneously reducing the weight for consumer use.

Figure 67: Spot Size using Plano-Convex Cylindrical Lenses and Thorlabs L904P010 905 nm Near Infrared Laser Diode (No Permission Needed)



What is important to be seen in the figures above is the different in beam quality and shape of the lens combination. In one image, the spot size is hardly recognizable. The combination of the two plano-convex cylindrical lenses allow us to have a circular collimated beam which is critical for the implementation of the laser triangulation system.

7.2.2 Spectrum

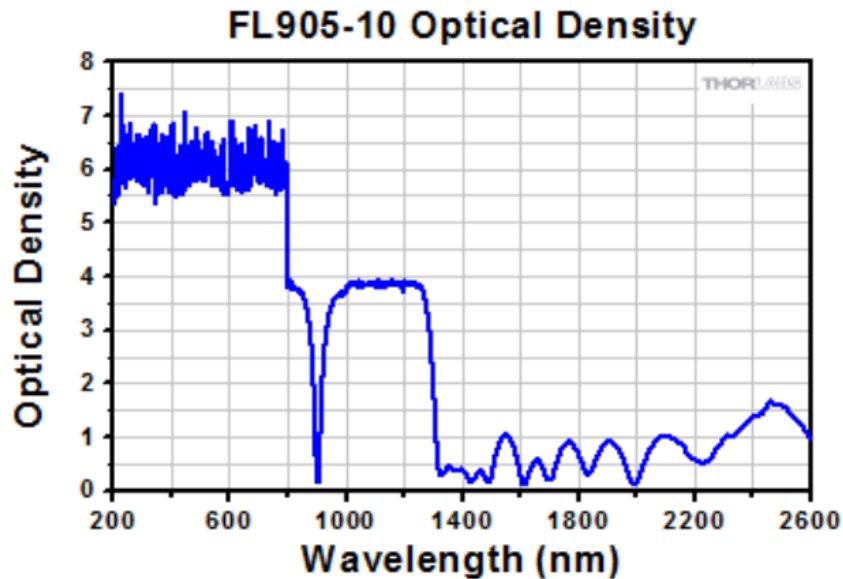
The spectrum emitted from the laser diode will be recorded using a Ocean Optics spectrometer. The purpose of this procedure is to ensure that the wavelength range of our transmitter corresponds to the range of sensitivity for the detector. If the spectral linewidth of our device is also too broad it can be seen to impact the optic we used to collimate our systems as seen in the Zemax simulation conducted in the lens selection system. Furthermore, if the wavelength emitted from the laser diode does not correspond to the spectral response of the CMOS detector then the responsivity will be negatively impacted. The CMOS detectors were selected to get an optimized response from the laser wavelength of 905 nm. The spectrum of the laser diodes were verified with the data sheets provided by ThorLabs. By keeping the spectral linewidth of the laser triangulation system narrow, we also ensure that our device adheres to the laser safety standards.

7.2.3 Bandpass Filter Testing

The bandpass filter verification will be done using a spectrometer, LED, and the infrared laser diode. First the optical spectrum of the LED will be recorded using an Ocean Optics spectrometer independently. After this procedure, the spectrum of the LED will be recorded once it has passed through the bandpass filter. The bandpass filter we selected should not allow for any of the visible spectrum of the LED to be collected by the Ocean Optics spectrometer. Following this step, the same procedure is done with the 905 nm infrared laser diode we selected.

From this information, we were able to verify and show the optical spectrum acceptance range of the bandpass filter which will go onto our CMOS camera. The datasheet of the bandpass filter provided by thorlabs confirmed the results. The bandpass filter will help filter out ambient light and help optimize the performance of the laser triangulation system.

Figure 68: Optical Bandpass Filter (Permission requested)



From this, we can see that our light centered at 905 nm should experience very little absorption through the medium, while light of almost all surrounding wavelengths is highly filtered. Longer wavelengths in the infrared regime also experience a low loss through this filter, but will not interact with our silicon detector. As such this filter should greatly benefit our SNR.

7.2.4 Laser Triangulation System Testing

The testing of the laser triangulation system will be conducted by comparing the experimental data calculated versus measuring the physical world distance to the target object. The target object selected in this experiment was a highly reflective white target (piece of white paper).

Data comparing the experimental data of the laser triangulation system and measured distances will be done to check the calibration of the system and to incorporate any manipulations needed to be programmed to get a more accurate reading. Different environments and different objects will always impact what you are able to detect using the laser triangulation system. The implementation in the final prototype will heavily rely on this step.

The slight deviation in values can be attributed to surface material properties (reflectivity, absorbance) as well as the medium the light propagates through before it reaches the detector. It is known by that atmospheric conditions (rain, fog) can result in light scattering. Common types of scattering that can occur include

The impact is that signal strength can decrease or potentially become even non-existent.

7.3 Software Testing

The software will be written in the Texas Instruments Integrated Development Environment (IDE) called Code Composer Studio Version 7 (CCS). Following the V-Model software development plan, we will be testing and deploying sections of code at a time to test functionality on the MSP430F6459 Launchpad. The Launchpad is a development board offered by Texas Instruments. This board will allow us to load the software onto the MSP430F6459 chip through a micro USB interface. The functionality of our hardware peripherals can then be tested by interfacing with the MSP430F6459 Launchpad board.

8. Administrative Content

This section shows the process to ensure the successful completion of the project. The first section addresses the timeline for our project as well as the execution of tasks leading up to our final presentation. The second section addresses the budget breakdown of all the components used in our project.

8.1 Milestone Discussion

In order to have a successful project execution, we planned out the two semesters of time that we had the opportunity to use. During the time of brainstorming ideas, we put together the following two tables with our goals and dates we wanted to accomplish them by. For the first semester, documentation was our primary focus. By breaking the 15 weeks up into chunks according to assignment deadline, as well as some intermediate tasks, we were able to set and meet the interval due dates and were not as overwhelmed.

After finals end on December 3rd we plan on meeting 4 times a week for 4 hour blocks to work in the lab and get our prototype functioning and ultimately meeting our requirement specifications. By the end of Senior Design 1 all of the components we have purchased should have been test to confirm that they are all working as intended and matching the data sheets provided by the company.

Table 25: Senior Design 1 Milestones

Item	Duration	Dates
Brainstorming/Project Identification	3½ Weeks	August 20 th 2018 - September 10 th 2018
Initial Project and Group Identification Document	1 week	September 10 th 2018 - September 14 th 2018
Updated Initial Project Documentation	2 weeks	September 15 th 2018- September 28 th 2018
Initial Device and Product Research with Florida Division of Blind Services	4 weeks	September 21 st 2018 - October 19 th 2018
Initial Designs and Seek Funding	2 weeks	October 5 th 2018 - October 19 th 2018
60 Page Draft	2 weeks	October 19 th 2018 - October 26 th 2018

Begin to Order Project Parts	Ongoing	October 26 th 2018
80 Page Draft	Milestone	November 8 th 2018
Design Drafts / Breadboarding (Laser Diode Driver critical)	2 ½ weeks	November 2 nd 2018 - November 16 th 2018
100 Page Draft	2 ½ weeks	November 2 nd 2018 - November 16 th 2018
Collimate NIR Laser Diode and Evaluate Lens Schematics	2 Weeks	November 16 th 2018 - December 3 rd 2018
Image a Laser Spot onto Camera	2 Weeks	November 16 th 2018 - December 3 rd 2018
Final Draft	2 ½ weeks	November 17 th 2018 - December 3 rd 2018

For the second semester, we have to build our product by constructing, testing, and finalizing our prospective designs. The following table shows the breakdown of how we decided to plan for those objectives leading up to the final presentation of our product. One key part to stress during this phase is that communication is paramount between group members as we progress on our individual parts. This is especially true if we encounter obstacles on our critical components of our project such as the software development for image processing. This will prevent the problem where we have a whole bunch of individual components that work separately, but we are unable to integrate them together into the system. The first phase will be to ensure that the laser diode is collimated for the working distance of object detection between 1 m - 2 m. The second phase will be to image a laser spot onto a CMOS detector. The third phase will consist of reading an analog output from the CMOS detector and feeding it into the microcontroller. The 4th phase will be the development of software to analyze the analog output and send a response to the feedback circuit. The final phase will be working to package all the components to match our engineering and marketing requirements.

Table 26: Senior Design 2 Milestones

Item	Duration	Dates
Prototype Construction	4 weeks	January 4 th 2019 - February 1 st 2019

Testing and Redesign	4 weeks	February 2 nd 2019 - March 1 st 2019
Final Prototype	4 weeks	March 1 st 2019 - April 1 st 2019
Peer Presentation	3 weeks	April 2019
Final Report	5 weeks	May 2019
Final Presentation	5 weeks	May 2019

8.2 Budget and Finance Breakdown

Before our group began designing or purchasing parts, we made a breakdown of projected costs. Because our project was not a sponsored project but was to be self funded, we agreed that we would collectively provide internal funding as a primary source of purchasing power and would seek external funding if at all possible. The team plans to seek funding from the Office of Diversity and Inclusion at UCF, Student Accessibility Services at UCF, Florida Division of Blind Services, Luminar, IEEE Photonics Society, and Student Government Association at UCF. The Lockheed Martin Innovation lab at Missiles & Fire Control has also given us access to use their 3D printers for free which is why the Opto-mechanical components will be free for this project. The printed circuit board was free due to Quality Manufacturing Services (QMS) and their generosity. Texas Instruments was kind enough to provide to us free of charge our microcontroller as well as additional parts for testing purposes.

Table 27: Budget and Finance Breakdown

Item #	Part	Cost
1	Printed Circuit Board	\$0
2	PCB Components	\$40.00
3	Main Controller Unit	\$0
4	Rechargeable Battery Bank	\$20.00
5	NIR Laser Diode	\$26.00
6	CMOS Camera	\$25.00
7	Plano-Convex Cylindrical Lenses	\$130.00

8	Optomechanics	\$0
9	Bandpass Filter	\$45.00
10	Neutral Density Filters	\$0
11	Device Housing	\$0
12	Location module	\$TBD
Total		\$ 286+

8.3 Project Design Problems

Our project did not end up in exactly the same way that we had initially we set out to design HeadsUp. Here are just a few of the things that did not go as planned:

- Our team took a few weeks longer than we would have liked deciding on a project to carry out. We had a few brainstorming meetings that were intended to help us decide on a project that gave enough work to two Photonics Engineers, one Computer Engineer, and one Electrical Engineer. We also wanted the project to be helpful to some demographic of people. Because we found there to be a limited number of ideas in this realm, we spent more time than desired and would have liked to put that time towards research and designing earlier.
- After many weeks of researching and designing for a LIDAR system that utilized a beam splitter and optical t_0 , we ultimately decided with the help of some advising that the power return and complication of timing electronics were just not feasible for our time constraints. We ended up going with laser triangulation which did not force us to sacrifice any functionality of the device and in fact saved us money (as beam splitters are not cheap).
- As mentioned in the *Executive Summary*, there were also a few stretch-goal features that we unfortunately did not get to implement. Not obtaining stretch-goals is part of product development and while we would like to implement them with more time, we are very proud of all that HeadsUp does accomplish in its current iteration.
- Another more practical obstacle was not meeting together as frequently as we would have liked, since each of us lived off campus in various directions and have competing work schedules. We intend to put more effort to meet together more frequently over our break and in Senior Design II.

8.4 Looking Forward

We hope that HeadsUp is able to positively impact those who use it and those who hear of it. Our efforts would be greatly fulfilled if our device promotes greater confidence, inspiration and imagination in blind individuals and others who have a desire to build products with the intentions of helping those who may benefit from it.

We know that we have been inspired by this project and are grateful for the opportunity to create HeadsUp.

In Senior Design II, we will be doing additional prototyping and testing for HeadsUp to build a final, packaged version that will be the capstone of our year-long project.

Appendix A - Copyright Permissions

RE: Permission to Use LIDAR Graphic

Jake Li <JLi@hamamatsu.com>

Wed 11/28/2018 10:37 PM

To: Duc-Quy Nguyen <ducquy.nguyen@Knights.ucf.edu>;

Cc: Alex Radulescu <aradulescu1@Knights.ucf.edu>; Hunter Tanchin <ju1c3box@Knights.ucf.edu>; Austin Singh <austin.singh72@Knights.ucf.edu>;

Hi Duc-Quy,

Thank you for reaching out and you have our permission to use this graphics.

Please put a small reference to hamamatsu.

Thank you and very best,

Sincerely,

Jake Q Li

HAMAMATSU

PHOTON IS OUR BUSINESS

Business Development Manager – Auto LiDAR

(C) 908.202.3432

<http://www.hamamatsu.com>

From: Duc-Quy Nguyen [mailto:ducquy.nguyen@Knights.ucf.edu]

Sent: Wednesday, November 28, 2018 10:34 PM

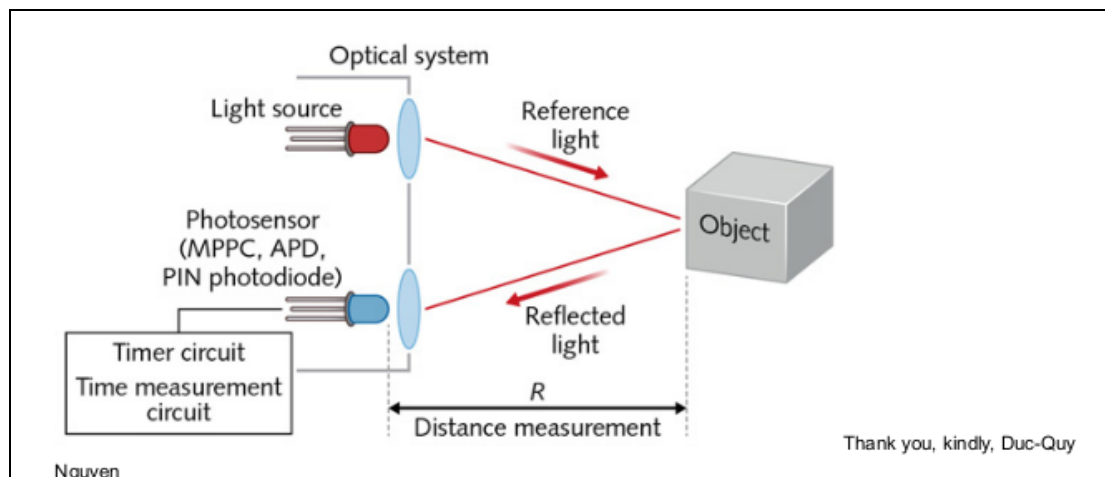
To: Jake Li <JLi@hamamatsu.com>

Cc: Alex Radulescu <aradulescu1@Knights.ucf.edu>; Hunter Tanchin <ju1c3box@Knights.ucf.edu>; Austin Singh <austin.singh72@Knights.ucf.edu>

Subject: Permission to Use LIDAR Graphic

Greetings Mr. Li, My name is Duc-Quy Nguyen. I am a student at The University of Central Florida and part of a small team that is designing a year-long senior design project. I write to you because your website includes a graphic that we feel would be well suited in providing helpful visuals in our documentation guide.

Would you be willing to give your permission to use this graphic in our paper?



RE: Permission to use Graphic

Batuhan Demir <batuhan.demir@yga.org.tr>

Thu 11/29/2018 1:55 AM

To: Duc-Quy Nguyen <ducquy.nguyen@Knights.ucf.edu>;

Cc: Austin Singh <austin.singh72@Knights.ucf.edu>; Alex Radulescu <aradulescu1@Knights.ucf.edu>; Hunter Tanchin <ju1c3box@Knights.ucf.edu>; WeWALK Help <hello@wewalk.io>;

1 attachments (409 KB)

WeWALK Core Info.pdf;

Hello Duc-Quy,

This is Batuhan from WeWALK team, thank you for reaching out to us.

Yes, you can use the mentioned graphic for your academic paper. May I also ask for what topic are you designing your project?

Attached, I am also sending WeWALK's one page summary document in case it's needed.

Kind Regards,
Batuhan Demir

From: Duc-Quy Nguyen [mailto:ducquy.nguyen@Knights.ucf.edu]

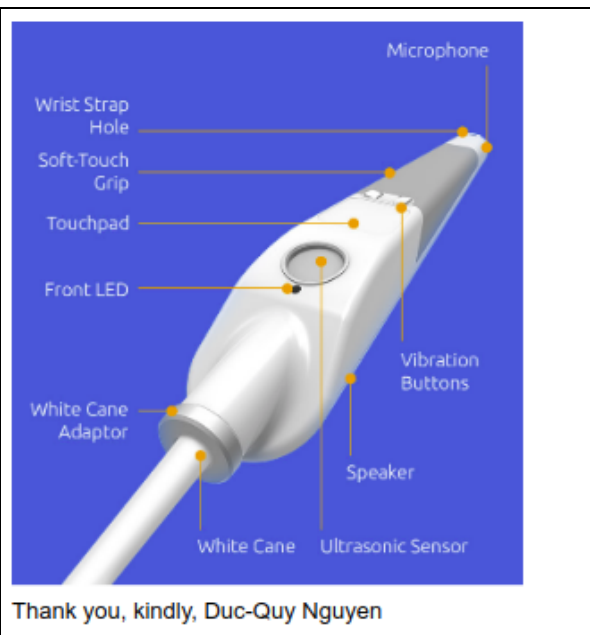
Sent: 29 November 2018 06:22

To: WeWALK Press <press@wewalk.io>; WeWALK Support <support@wewalk.io>; WeWALK Help <hello@wewalk.io>

Cc: Austin Singh <austin.singh72@Knights.ucf.edu>; Alex Radulescu <aradulescu1@Knights.ucf.edu>; Hunter Tanchin <ju1c3box@Knights.ucf.edu>

Subject: Permission to use Graphic

Greetings WeWalk Team, My name is Duc-Quy Nguyen. I am a student at The University of Central Florida and part of a small team that is designing a year-long senior design project. I write to you because your website includes a graphic that we feel would be well suited in providing helpful visuals in our documentation guide. Would you be willing to give your permission to use this graphic in our paper?



Duc-Quy Nguyen <ducquy.nguyen@Knights.ucf.edu>

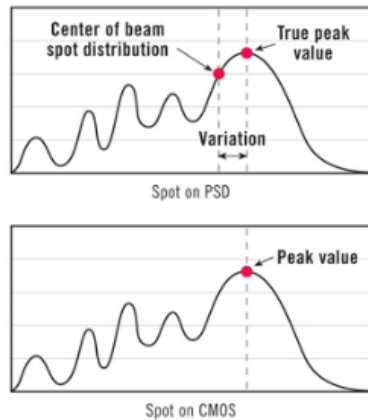
Wed 11/28/2018 10:55 PM

To: sales@mtiinstruments.com <sales@mtiinstruments.com>;

Cc: Alex Radulescu <aradulescu1@Knights.ucf.edu>; Hunter Tanchin <julc3box@Knights.ucf.edu>; Austin Singh <austinsingh72@Knights.ucf.edu>;

Greetings MTI Instruments Team,

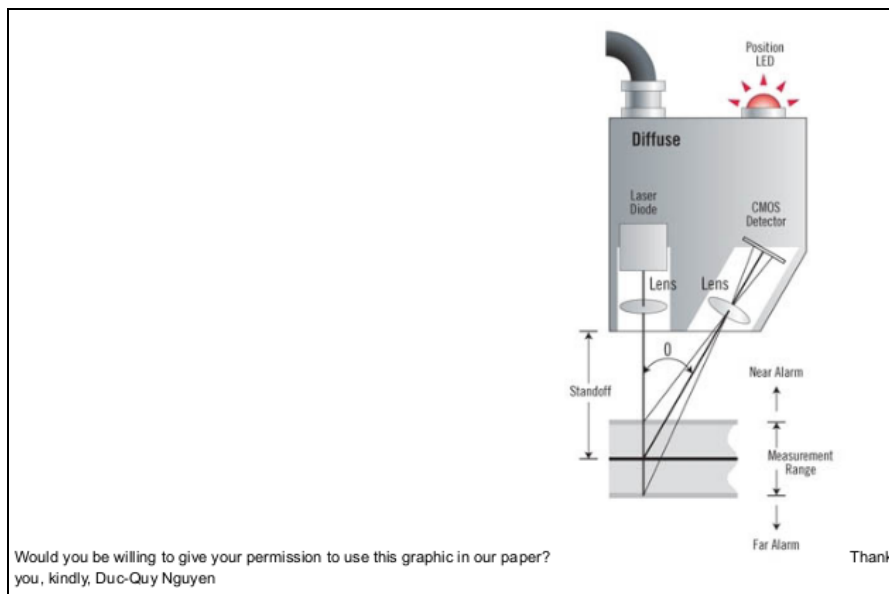
We would also like to cite this graphic if possible. Thank you so much for the help!



Best,
Duc-Quy Nguyen

From: Duc-Quy Nguyen
Sent: Wednesday, November 28, 2018 7:44:04 PM
To: sales@mtiinstruments.com
Cc: Alex Radulescu; Hunter Tanchin; Austin Singh
Subject: Permission to Use Laser Triangulation Graphics

Greetings MTI Instruments Team, My name is Duc-Quy Nguyen. I am a student at The University of Central Florida and part of a small team that is designing a year-long senior design project. I write to you because your website includes a graphic that we feel would be well suited in providing helpful visuals in our documentation guide.



Permission to Use LaserCane Graphic

Duc-Quy Nguyen <ducquy.nguyen@Knights.ucf.edu>

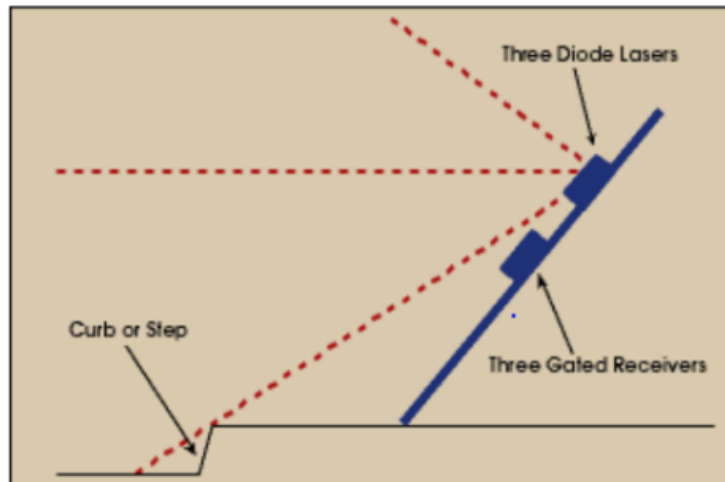
Wed 11/28/2018 10:30 PM

To: info@photonics.com <info@photonics.com>; editorial@photonics.com <editorial@photonics.com>;

Cc: Austin Singh <austin.singh72@Knights.ucf.edu>; Alex Radulescu <aradulescu1@Knights.ucf.edu>; Hunter Tanchin <ju1c3box@Knights.ucf.edu>;

Greetings Photonics Media, My name is Duc-Quy Nguyen. I am a student at The University of Central Florida and part of a small team that is designing a year-long senior design project. I write to you because your website includes a graphic that we feel would be well suited in providing helpful visuals in our documentation guide.

Would you be willing to give your permission to use this graphic in our paper?



Thank you, kindly, Duc-Quy Nguyen

Permission to Use Graphic

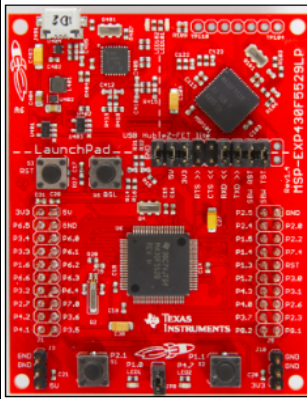
Hunter Tanchin

Mon 12/3/2018 9:18 AM

To: univ@ti.com <univ@ti.com>;

Greetings, My name is Hunter. I am a student at The University of Central Florida and part of a small team that is designing a year-long senior design project. I write to you because your website includes a graphic that we feel would be well suited in providing helpful visuals in our documentation guide. Would you be willing to give your permission to use this graphic in our paper?

Thank you,
Hunter T.



From: Duc-Quy Nguyen
Sent: Wednesday, November 28, 2018 8:19:53 PM
To: university@microchip.com
Cc: Alex Radulescu; Austin Singh; Hunter Tanchin
Subject: Permission to Use Arduino Graphic

Greetings Microchip Team,

My name is Duc-Quy Nguyen. I am a student at The University of Central Florida and part of a small team that is designing a year-long senior design project.

I write to you because your website includes a graphic that we feel would be well suited in providing helpful visuals in our documentation guide.

Would you be willing to give your permission to use this graphic in our paper?



Thank you, kindly,
Duc-Quy Nguyen

Re: Permission to Use Arduino Graphic

Duc-Quy Nguyen <ducquy.nguyen@Knights.ucf.edu>

Wed 11/28/2018 11:22 PM

To: university@microchip.com <university@microchip.com>;

Cc: Alex Radulescu <aradulescu1@Knights.ucf.edu>; Austin Singh <austinsingh72@Knights.ucf.edu>; Hunter Tanchin <ju1c3box@Knights.ucf.edu>;

Dear Microchip team,

We would also like to cite the **PIC24FJ128GC010 Microcontroller**.



Thank you for the help!

Best,
Duc-Quy Nguyen

Permission to Use Michelson Interferometer Graphic

Duc-Quy Nguyen <ducquy.nguyen@Knights.ucf.edu>

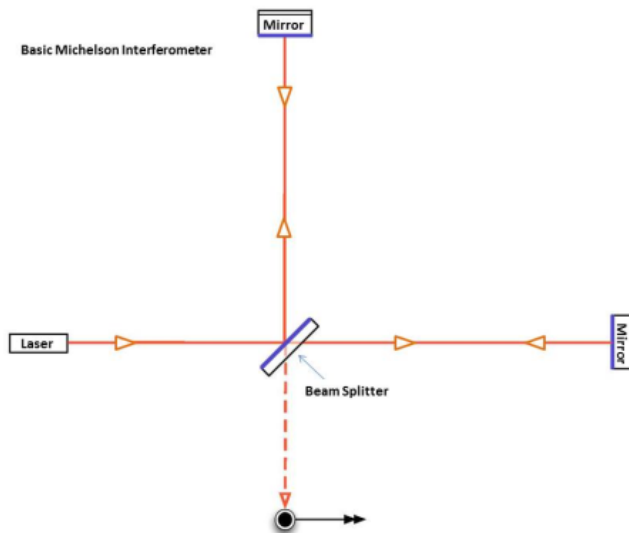
Wed 11/28/2018 10:37 PM

To: giaime@ligo-la.caltech.edu <giaime@ligo-la.caltech.edu>; landry_m@ligo-wa.caltech.edu <landry_m@ligo-wa.caltech.edu>;

Cc: Austin Singh <austin.singh72@Knights.ucf.edu>; Alex Radulescu <aradulescu1@Knights.ucf.edu>; Hunter Tanchin <ju1c3box@Knights.ucf.edu>;

Greetings LIGO Team, My name is Duc-Quy Nguyen. I am a student at The University of Central Florida and part of a small team that is designing a year-long senior design project. I write to you because your website includes a graphic that we feel would be well suited in providing helpful visuals in our documentation guide.

Would you be willing to give your permission to use this graphic in our paper?



Thank you, kindly, Duc-Quy Nguyen

Permission to Use iGlasses Graphic

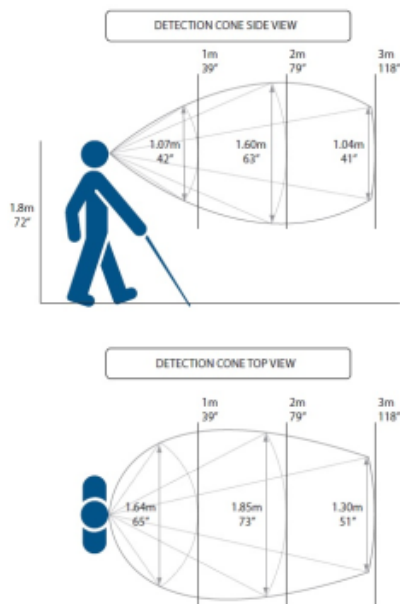
Duc-Quy Nguyen <ducquy.nguyen@Knights.ucf.edu>

Wed 11/28/2018 10:26 PM

To: orders@ambutech.com <orders@ambutech.com>;

Cc: Alex Radulescu <aradulescu1@Knights.ucf.edu>; Austin Singh <austin.singh72@Knights.ucf.edu>; Hunter Tanchin <ju1c3box@Knights.ucf.edu>;

Greetings AmbuTech team, My name is Duc-Quy Nguyen. I am a student at The University of Central Florida and part of a small team that is designing a year-long senior design project. I write to you because your website includes a graphic that we feel would be well suited in providing helpful visuals in our documentation guide. Would you be willing to give your permission to use this graphic in our paper?



Detection ranges indicated are based on tests with a 110mm diameter object.

Thank you, kindly, Duc-Quy Nguyen

Permission to Use Specular and Diffuse Reflection Graphic

Duc-Quy Nguyen <ducquy.nguyen@Knights.ucf.edu>

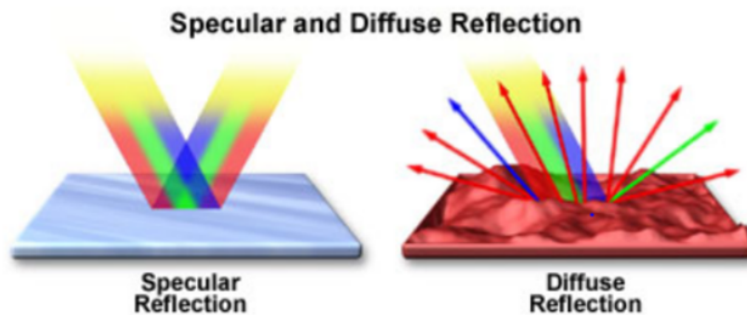
Wed 11/28/2018 10:39 PM

To: eclark@magnet.fsu.edu <eclark@magnet.fsu.edu>;

Cc: Austin Singh <austin.singh72@Knights.ucf.edu>; Alex Radulescu <aradulescu1@Knights.ucf.edu>; Hunter Tanchin <ju1c3box@Knights.ucf.edu>;

Greetings, My name is Duc-Quy Nguyen. I am a student at The University of Central Florida and part of a small team that is designing a year-long senior design project. I write to you because your website includes a graphic that we feel would be well suited in providing helpful visuals in our documentation guide.

Would you be willing to give your permission to use this graphic in our paper?



Thank you, kindly, Duc-Quy Nguyen

Permission to Use Graphic

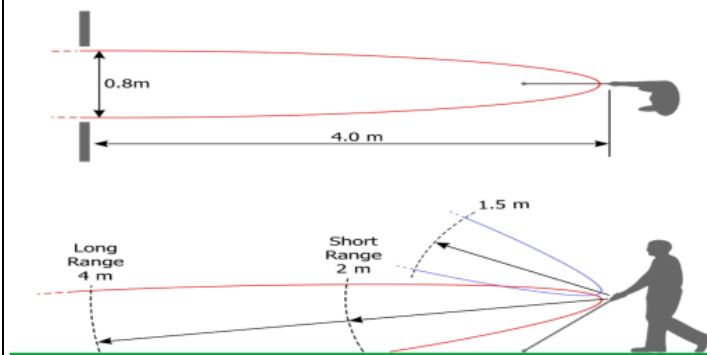
Duc-Quy Nguyen <ducquy.nguyen@Knights.ucf.edu>

Wed 11/28/2018 10:18 PM

To: sales@ultracane.com <sales@ultracane.com>;

Cc: Austin Singh <austin.singh72@Knights.ucf.edu>; Hunter Tanchin <ju1c3box@Knights.ucf.edu>; Alex Radulescu <aradulescu1@Knights.ucf.edu>;

Greetings UltraCane team, My name is Duc-Quy Nguyen. I am a student at The University of Central Florida and part of a small team that is designing a year-long senior design project. I write to you because your website includes a graphic that we feel would be well suited in providing helpful visuals in our documentation guide. Would you be willing to give your permission to use this graphic in our paper?



Thank you, kindly, Duc-Quy Nguyen

Order confirmation - TS2169384; PO# N21W723069



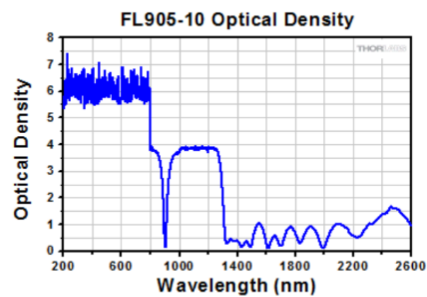
Duc-Quy Nguyen

Today, 11:04 PM

Andrew Lister <ALister@thorlabs.com>

Hello,

I would like to request permission to use this graphic in a document for my senior design report on the band pass filter. Would that be okay? Thanks!



Best,
Duc-Quy Nguyen

...



Andrew Lister <ALister@thorlabs.com>

Thank you for your order! Please find attached your order confirmation, indicating all items are currently in stock. If you need to make any immediate changes or see any discrepancies, please con...



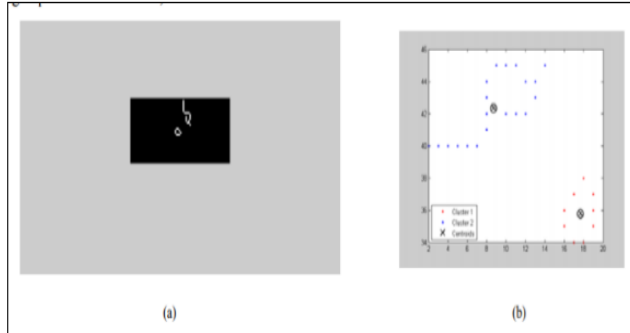
Duc-Quy Nguyen

Today, 7:35 PM

salleh@eng.ukm.my; Austin Singh; Hunter Tanchin; Alex Radulescu

Greetings,

My name is Duc-Quy Nguyen. I am a student at The University of Central Florida and part of a small team that is designing a year-long senior design project. I write to you because your website includes a graphic that we feel would be well suited in providing helpful visuals in our documentation guide. Would you be willing to give your permission to use this graphic in our paper?



Thank you, kindly,
Duc-Quy Nguyen

Absolutely. Permission granted. Cheers! mjs

Duc-Quy Nguyen

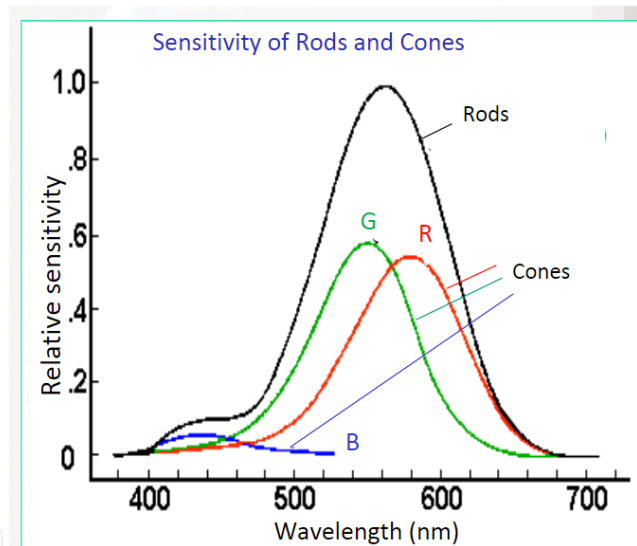
Mon 10/22, 9:04 AM

M.J. Soileau

Sent Items

Good morning Dr. Soileau,

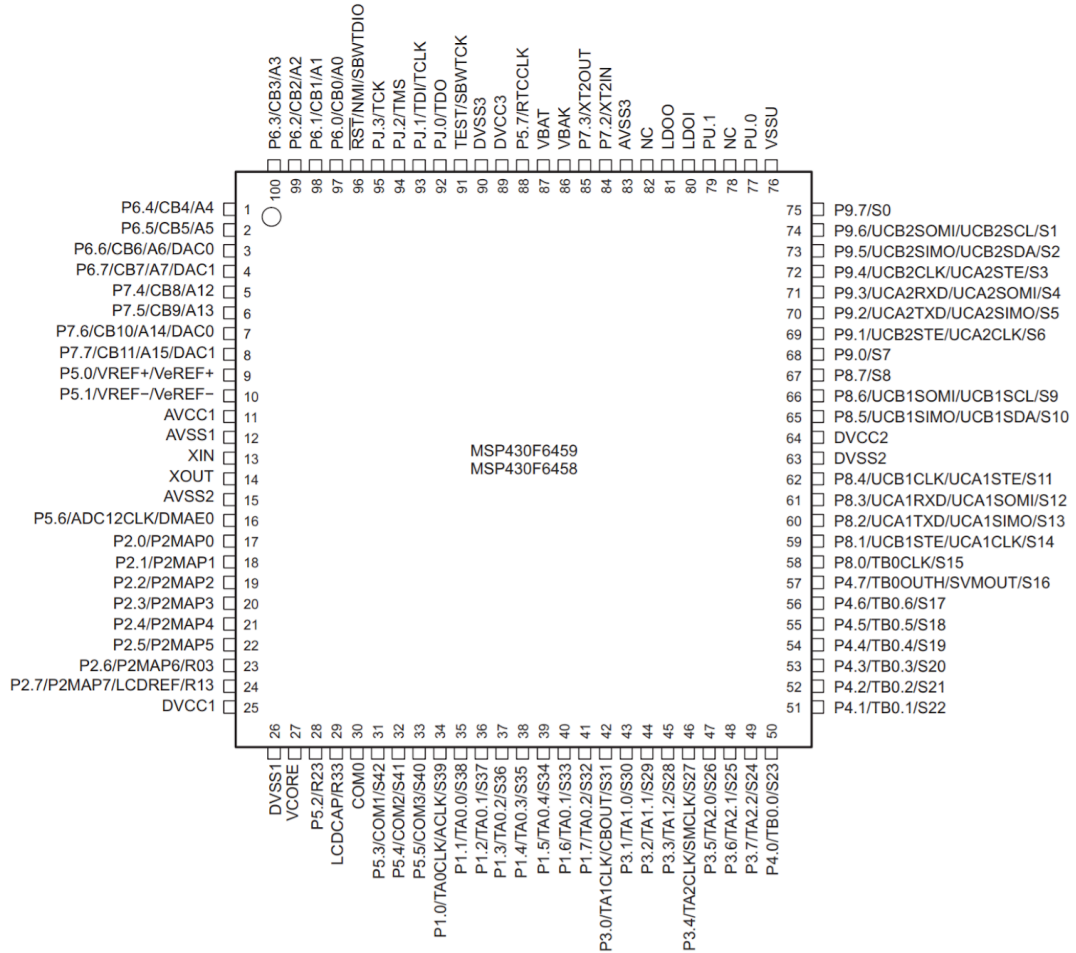
I was wondering if I could get your permission to use one of your graphics from Visual Optics in Austin and I's senior design document? We plan on using it to talk about why we chose our wavelength for our optical navigation guide for the blind. Thanks and I hope you are doing well!



Appendix B - Datasheets Appendix

MSP430F6459IPZR Microcontroller Datasheet: <http://www.ti.com/lit/ds/symlink/msp430f6459.pdf>

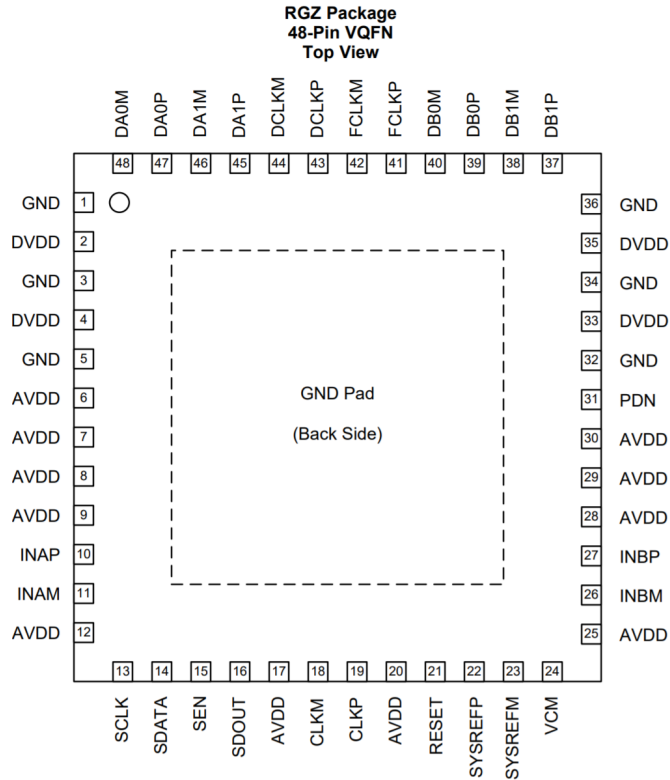
Pinout:



ADC3244IRGZT Analog-to-Digital Converter Datasheet:

<http://www.ti.com/lit/ds/symlink/adc3244.pdf>

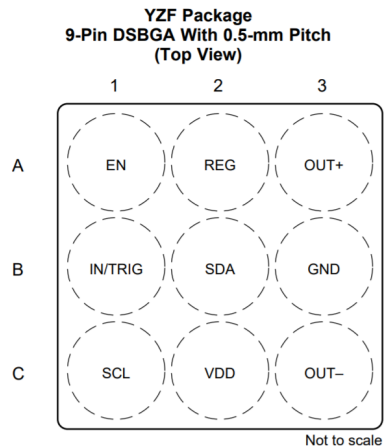
Pinout:



DRV2605LDGSR Haptic Driver Datasheet:

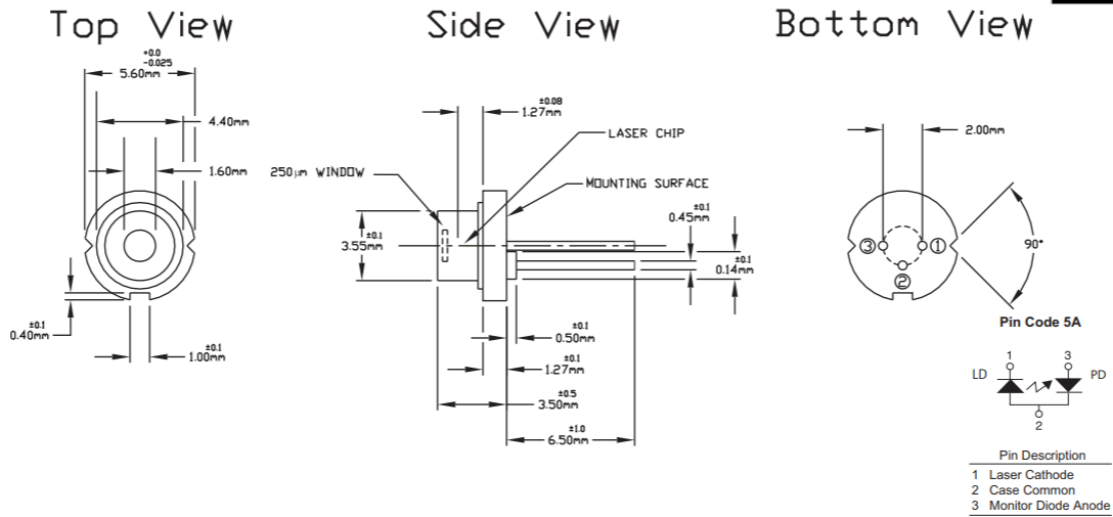
<http://www.ti.com/lit/ds/symlink/drv2605.pdf>

Pinout:



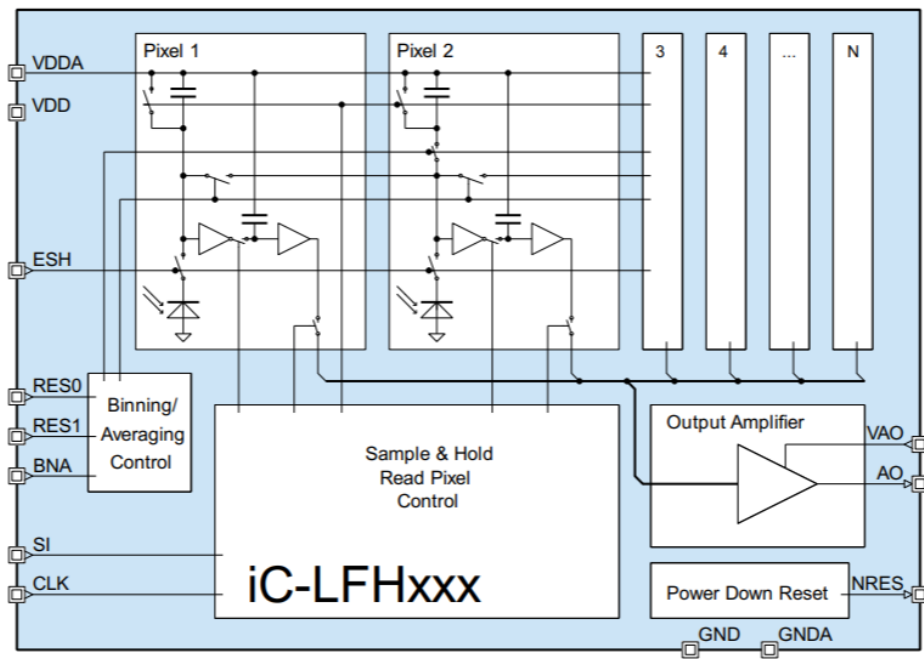
ThorLabs L904P010 Laser Diode

<https://www.thorlabs.com/drawings/ce5e5f519cd8e4f8-8CC7823D-00DF-B503-6861094A13EFD664/L904P010-SpecSheet.pdf>



iCHaus LFH-320 Linear Image Sensor

<https://www.semiconductorstore.com/pages/asp/DownloadDirect.asp?sid=1543818523450>



Appendix C - Works Cited

1. Organization, W.H., *Global Data on Visual Impairments*. 2010.
2. Moran, S.E. *Walking stick with lasers helps visually impaired detect objects*. The Associated Press, 2003.
3. *Reaction Time Statistics*. 2018; Available from: <https://www.humanbenchmark.com/tests/reactiontime/statistics>.
4. *Ultracane*. 2018
Available from: <https://www.ultracane.com/>.
5. *WeWalk*. 2018.
6. *Blindsquare*. 2018.
7. *Navigon*. 2018.
8. Wiberg, H. *BeMyEyes*. 2018; Available from: <https://www.bemyeyes.com/about>.
9. *AIRA*. 2018; Available from: <https://aira.io/pricing>.
10. *Campus Bird*. 2018; Available from: <http://www.campusbird.com/>.
11. Sergio I. Lopes, J.M.N.V., Oscar F.F. Lopes, Pedro R.M. Rosa, *MobiFree: A Set of Electronic Mobility Aids for the Blind*. ELSEVIER, 2012.
12. *iGlasses*. 2018; Available from: <https://ambutech.com/shop-online/iglasses%E2%84%A2-ultrasonic-mobility-aid>.
13. Hitz, B. *Lasers Assist the Blind*. 2003.
14. Garry Berkovic, E.S., *Optical methods for distance and displacements measures*. Optical Society of America, 2012.
15. Markus-Christian Amann, T.B., Marc Lescure, Risto Myllyla, Marc Rioux, *Laser ranging : a critical review of usual techniques for distance measurements*. SPIE, 2001.
16. *LIGO*. 2015; Available from: <https://www.ligo.caltech.edu/page/what-is-interferometer>.
17. Epsilon, M., *Using Laser Triangulation Technology for Reliable Measurements of Manufactured Components*. 2017.
18. *Displacement Sensors/Measurement Sensors*. 2018; Available from: <http://www.ia.omron.com/support/guide/56/introduction.html>.
19. Breier, M. *Accurate laser triangulation using a perpendicular camera setup to assess the height profile of PCBs*. 2015. IEEE.
20. Shojaeipour, S., *Robot path obstacle locator using webcam and laser emitter*. 2010. **Physics Procedia**.
21. Julight. *Laser Triangulation*. 2014; Available from: <http://www.julight.it/laser-triangulation/>.

22. Kasap, *Optoelectronics & Photonics*. 2013.
23. mtiinstruments. *Laser Triangulation Sensors*. 2018; Available from: <https://www.mtiinstruments.com/technology-principles/laser-triangulation-sensors/>.
24. Moynihan, T. *CMOS Is Winning the Camera Sensor Battle, and Here's Why*. 2011; Available from: <https://www.techhive.com/article/246931/security-cameras/cmos-is-winning-the-camera-sensor-battle-and-heres-why.html>.
25. Allen, G. *After Hurricane Michael, A Call For Stricter Building Codes in Florida's Panhandle*. 2018.
26. ANSI. *Laser Standards and Classifications*. 2018; Available from: <https://www.rli.com/resources/articles/classification.aspx>.
27. *Laser Glossary*. 2018; Available from: https://ehs.oregonstate.edu/sites/ehs.oregonstate.edu/files/laser_glossary_full.pdf.
28. Standards, I.O.f. *Systems and software engineering -- Software life cycle processes*. 2017; Available from: <https://www.iso.org/standard/63712.html>.
29. ADA, *Wheelchairs, Mobility Aids, and Other Power-Driven Mobility Devices* 2010.
30. rscasny. *Comparing an FPGA to a Microcontroller, Microprocessor or an ASIC*. 2018; Available from: <https://www.element14.com/community/groups/fpga-group/blog/2018/02/22/comparing-an-fpga-to-a-microcontroller-microprocessor-or-an-asic>.
31. Kent, *Written Program Size: A Comparison of C vs Assembly*. 2011.
32. Varotsis, A.B. *CNC Machining vs 3D Printing*. 2018; Available from: <https://www.3dhubs.com/knowledge-base/3d-printing-vs-cnc-machining>.
33. *Clear Aperture*. 2018.